

1.General Crane Scale(OCS-A)



Features:

30mm(1.2") LED display Remote control calibration
Easy to replace battery pack AC/DC power adaptor:output DC9V/1.5A
6 V/10Ah rechargeable battery Infrared remote controller,distance:20m
Hold, tare, accumulation, kg/lb conversion , gross/net conversion parameter regulation

Specification:

Accuracy Class	OIML Class III
Display 30mm(1.2")	5 digits LCD
Tare Range	Full capacity
Stable Time	<10 seconds
Overload Indication	100% Max. capacity + 9e
Max. Safety Load	125% Max. capacity
Ultimate Load	400% Max. capacity
Operation time	60 hours min/100 hours max
Battery Type	Fully sealed lead-acid battery, 6V/10Ah
Charger	DC9V/1500mA
Operating Temp	-10°C - +40°C
Operating Humidity	< 85% RH under 20°C
Battery of Remote Controller	5# battery, 1.5V x 2

Max Cap / Division (e) / Number (n)

MODEL	Max Cap	(kg)	(n)
OCS-1-A	1000kg	0.5	2000
OCS-2-A	2000kg	1	2000
OCS-3-A	3000kg	1	3000
OCS-5-A	5000kg	2	2500
OCS-10-A	10000kg	5	2000
OCS-15-A	15000kg	5	3000
OCS-20-A	20000kg	10	2000

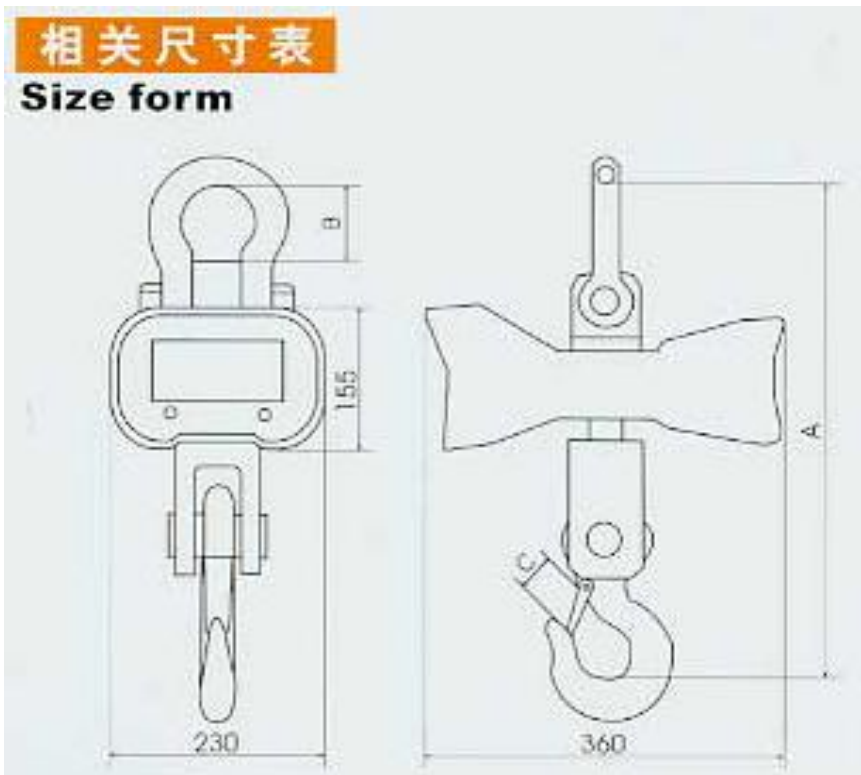

MODEL	A(mm)	B(mm)	C(mm)	N.W.
OCS-1-A	420	64	35	12kg
OCS-2-A	420	64	35	12kg
OCS-3-A	600	80	45	14kg
OCS-5-A	730	100	55	24kg
OCS-10-A	850	120	70	44kg
OCS-15-A	900	140	70	60kg
OCS-20-A	915	155	70	65kg

Accessory:



2. Portable crane scales



Features

30mm(1.2") LCD display Remote control calibration
 Easy to replace battery pack AC/DC power adaptor:output DC9V/1.5A
 6 V/10Ah rechargeable battery Infrared remote controller,distance:20m
 Hold, tare, accumulation, kg/lb conversion , gross/net conversion , parameter regulation

Specification

Accuracy Class	OIML Class III
Display	30mm(1.2") 5 digits LCD
Tare Range	Full capacity
Stable Time	< 10 seconds
Overload Indication	100% Max. capacity + 9e
Max. Safety Load	125% Max. capacity
Ultimate Load	400% Max. capacity
Operation time	60 hours min/100 hours max(depends on operation mode)
Battery Type	Fully sealed lead-acid battery, 6V/10Ah
Charger	DC9V/1500mA
Operating Temp	-10°C - +40°C

Operating Humidity < 85% RH under 20°C
 Battery of Remote Controller 5# battery, 1.5V x 2

MODEL	Max Cap	(kg)	(n)
OCS-005-M	50kg	0.02	2500
OCS-01-M	100kg	0.05	2000
OCS-02-M	200kg	0.1	2000
OCS-03-M	300kg	0.1	3000
OCS-05-M	500kg	0.2	2500
OCS-1-M	1000kg	0.5	2000

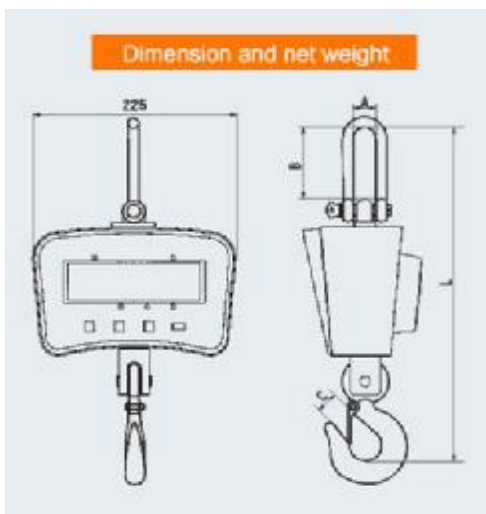

MODEL	A(mm)	B(mm)	C(mm)	N.W.
OCS-005-M	350	80	20	4kg
OCS-01-M	350	80	20	4kg
OCS-02-M	350	80	20	4kg
OCS-03-M	350	80	20	4kg
OCS-05-M	370	85	30	4.5kg
OCS-1-M	370	85	30	4.5kg

Accessory:



3.Heat Proof Crane Scales



Features

- 30mm(1.2") LCD display Remote control calibration
- Easy to replace battery pack AC/DC power adaptor:output DC9V/1.5A
- 6 V/10Ah rechargeable battery Infrared remote controller,distance:20m
- Hold, tare, accumulation, kg/lb conversion , gross/net conversion , parameter regulation

Specification

Accuracy Class	OIML Class III
Display	30mm(1.2") 5 digits LCD
Tare Range	Full capacity
Stable Time	< 10 seconds
Overload Indication	100% Max. capacity + 9e
Max. Safety Load	125% Max. capacity
Ultimate Load	400% Max. capacity
Operation time	60 hours min/100 hours max(depends on operation mode)
Battery Type	Fully sealed lead-acid battery, 6V/10Ah
Charger	DC9V/1500mA
Operating Temp	-10°C - +40°C
Operating Humidity	< 85% RH under 20°C
Battery of Remote Controller	5# battery, 1.5V x 2

Max Cap / Division (e) / Number (n)

MODEL	Max Cap	(kg)	(n)
OCS-1-G	1000kg	0.5	2000
OCS-2-G	2000kg	1	2000
OCS-3-G	3000kg	1	3000
OCS-5-G	5000kg	2	2500
OCS-10-G	10000kg	2	2000
OCS-15-G	15000kg	10	3000

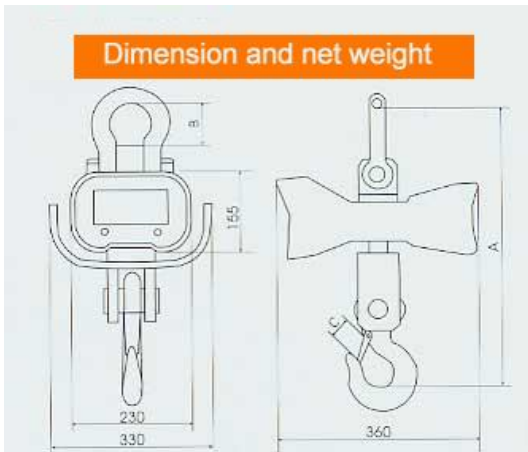

MODEL	A(mm)	B(mm)	C(mm)	N.W.
OCS-1-G	420	65	35	12kg
OCS-2-G	600	80	45	14kg
OCS-3-G	730	100	55	24kg
OCS-5-G	850	120	70	44kg
OCS-10-G	900	140	70	60kg
OCS-15-G	900	140	70	60kg

Accessory:



4. Wireless Crane Scales:



Features

Data wireless transmission
Internal clocks and calendar
Multiple print format
Division selection
Easy to replace battery pack
High-tension hook and shackle

Specification

Accuracy Class According to OIML III
Display 25mm high, 6 digits screen digits tube
Tare Range 100% F.S.
Stable Time ≤ 10 seconds
Overload Indication 100% F.S. + 9e
Max. Safety Load 125% F.S.
Ultimate Load 400% F.S.
Operation time ≥ 50 hours
Battery Type 12V/7Ah full sealed rechargeable battery
Charger AC220V/DC12V1500mA
Operating Temp -10°C - +40°C
Operating Humidity < 90% RH at 20°C
Battery of Remote Controller 5# battery, 1.5V × 2

Max Cap / Division (e) / Number (n)

MODEL	Max Cap	(kg)	(n)
OCS-1-Ea	1000kg	1	2000
OCS-2-Ea	2000kg	1	2000
OCS-3-Ea	3000kg	1	3000
OCS-5-Ea	5000kg	2	2500
OCS-10-Ea	10000kg	5	2000
OCS-15-Ea	15000kg	5	3000
OCS-20-Ea	20000kg	10	2000
OCS-30-Ea	30000kg	10	3000

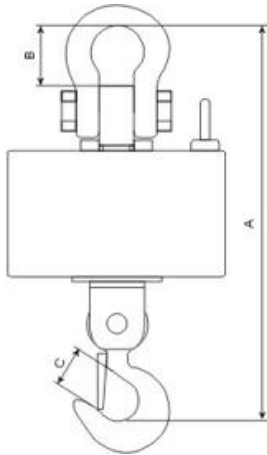

MODEL	A(mm)	B(mm)	C(mm)	N.W.
OCS-1-Ea	420	65	35	22kg
OCS-2-Ea	420	65	35	22kg
OCS-3-Ea	600	80	45	25kg
OCS-5-Ea	730	100	55	35kg
OCS-10-Ea	850	120	70	46kg
OCS-15-Ea	900	140	80	68kg
OCS-20-Ea	950	160	80	73kg
OCS-30-Ea	1120	180	90	155kg

Accessory:



5. Heavy Duty Crane Scales:



Features

All steel armour-clad enclosure, crashworthy and anticorrosion
56mm LED display, over 30m visual range
High accuracy steel alloy loadcell for stable and reliable measuring
Quality steel alloy load receptor against ultimate load of over 500% F.S
Considerable capacity long life rechargable battery
Remote controller, easy-to-use and convenient

Specification

Accuracy Class	OIML Class III
Display	30mm(1.2") 5 digits LCD
Tare Range	Full capacity
Stable Time	< 10 seconds
Overload Indication	100% Max. capacity + 9e
Max. Safety Load	125% Max. capacity
Ultimate Load	400% Max. capacity
Operation time	60 hours min/100 hours max(depends on operation mode)
Battery Type	Fully sealed lead-acid battery, 6V/10Ah
Charger	DC9V/1500mA
Operating Temp	-10°C - +40°C
Operating Humidity	< 85% RH under 20°C
Battery of Remote Controller	5# battery, 1.5V x 2

Max Cap / Division (e) / Number (n)

MODEL	MaxCap	(kg)	(n)
OCS-10-Z	10000kg	5	2000
OCS-15-Z	15000kg	5	3000
OCS-20-Z	20000kg	10	2000
OCS-30-Z	30000kg	10	3000
OCS-50-Z	50000kg	20	2500