

Caution for UL/cUL requirements

- The Hyundai Heavy Industry N700E inverter UL file number is E205705 .
Confirmation of UL listing can be found on the UL web site : www.ul.com
- Do not connect or disconnect wiring, or perform signal checks while the power supply is turned ON.
- There are live parts inside the inverter. Never touch the printed wiring board(PWB) while the power supply is turned ON.
- [Warning] The bus capacitor discharge time is 5 minutes. Before starting wiring or inspection, switch power off, wait for more than 5 minutes, and check for residual voltage between terminal P(+) and N(-) with a meter etc., to avoid hazard of electrical shock.
- [Short circuit rating] This inverter is suitable for use on a circuit capable of delivering not more than 5,000Arms symmetrical amperes, 480 volts for HF type and 240 volts for LF type maximum.
Branch circuit short circuit protection shall be provide by fuse only
- [Over speed protection] This inverter does not provide over speed protection.
- [Over load protection] This inverter provides motor over load protection.
Over load protection level is 50~200% of full load current. The protection level is 20~200% of full load current. The protection level may be adjusted by code b07. Refer to the N700E user guide or catalog.
- [Environment]

Maximum Surrounding Air temperature	40℃ (When Carrier Frequency equal to or less than Default Value) 50℃ (When Carrier Frequency equal to or less than 3 kHz, except equal to or less than 2kHz only for N700E-220 series)
Ambient humidity	90% RH or less(no condensing)
Storage temperature	-20~60℃
Vibration	5.9m/s ² or less
Altitude	Altitude 1,000m or less
Ambience	Indoors(No corrosive and flammable gases, oil mist, dust and dirt)
Pollution Degree	2

SAFETY

For the best Results with N700E Series inverter, read this manual and all of the warning sign attached to the inverter carefully before installing and operating it, and follow the instruction exactly. Keep this manual handy for your quick reference.

Definitions and Symbols

A safety instruction (message) is given with a hazard alert symbol and a signed word, **WARNING** or **CAUTION**. Each signal word has the following meaning throughout this manual.



This symbol means hazardous high voltage. It used to call your attention to items or operations that could be dangerous to you or other persons operating this equipment. Read these messages and follow these instructions carefully.



This is the "Safety Alert Symbol". This symbol is used to call your attention to items or operations that could be dangerous to you or other persons operating this equipment. Read these messages and follow these instructions carefully.



WARNING Indicates a potentially hazardous situation which, if not avoided, can result in serious injury or death.



CAUTION Indicates a potentially hazardous situation which, if not avoided, can result in minor to moderate injury, or serious damage of product. The matters described under  **CAUTION** may, if not avoided, lead to serious results depending on the situation. Important matters are described in **CAUTION** (as well as **WARNING**), so be sure to observe them.

NOTE Notes indicate an area or subject of special merit, emphasizing either the product's capabilities or common errors in operation or maintenance.



HAZARDOUS HIGH VOLTAGE

Motor control equipment and electronic controllers are connected to hazardous line voltage. When servicing drives and electronic controllers, there might be exposed components with cases or protrusions at or above line potential. Extreme care should be taken to protect against shock. Stand on an insulating pad and make it a habit to use only one hand when checking components. Always work with another person in case an emergency occurs. Disconnect power before checking controller or performing maintenance. Be sure equipment is properly grounded. Wear safety glasses whenever working on an Electric controller or rotating electrical equipment.

PRECAUTION



WARNING : This is equipment should be installed, adjusted and serviced by qualified Electrical maintenance personal familiar with the construction and operation of the Equipments and the hazards involved. Failure to observe this precaution could results In bodily injury.



WARNING : The user is responsible for ensuring that all driven machinery, drive train mechanism not supplied by HYUNDAI and process line material are capable of safe operation at an applied frequency of 150% of the maximum selected frequency range to the AC motor. Failure to do so can result in destruction of equipment and injury to personnel should a single point failure occur.



WARNING : For protection, install an earth leakage breaker with a high frequency circuit capable of large currents to avoid an unnecessary operation. The ground fault protection circuit is not designed to protect personal injury.



WARNING : Separate motor overcurrent, overload and overheating protection is required to be provided in accordance with the safety codes required by jurisdictional authorities.



WARNING : Dangerous voltage exists until charge lamp is off. Risk of electric shock. Ensure proper earth connection. Before opening the cover, wait at least 5 minutes Until DC bus capacitors are discharge.



CAUTION : Heavy object. To avoid muscle strain or back injury, use lifting aids and proper lifting techniques when removing or replacing.



CAUTION : These instructions should be read and clearly understood before working on N700E series equipment.



CAUTION : Proper grounds, disconnecting devices and other safety devices and their location are the responsibility of the user and are not provided by HYUNDAI.



CAUTION : Be sure to connect a motor thermal switch or overload devices to the N700E Series controller to assure that inverter will shut down in the event of an overload or an overheated motor



CAUTION: Rotating shafts and above ground electrical potentials can be hazardous. Therefore, it is strongly recommended that all electrical work conform to the National Electrical Codes and local regulations. Only qualified personnel should perform Installation, alignment and maintenance. Factory recommended test procedures, include in the instruction manual, should be followed. Always disconnect electrical power before working on the unit.

NOTE : POLLUTION DEGREE 2

The inverter must be used in the environment of the pollution degree 2.

Typical constructions that reduce the possibility of conductive pollution are,

- 1) The use of an unventilated enclosure
- 2) The use of a filtered ventilated enclosure when the ventilation is fan forced
That is, ventilation is accomplished by one more blowers within the enclosure that provide a positive intake and exhaust.

Caution for EMC (Electromagnetic Compatibility)

To safety the EMC directive and to comply with standard, follows the checklist below.



WARNING

This equipment should be installed, adjusted, and serviced by qualified personal familiar with Construction and operation of the equipment and the hazards involved.
Failure to observe this precaution could result in bodily injury.

1. The power supply to N700E inverter must meet these specifications
 - a. Voltage fluctuation $\pm 10\%$ or less.
 - b. Voltage imbalance $\pm 3\%$ or less.
 - c. Frequency variation $\pm 4\%$ or less.
 - d. Voltage distortion THD = 10% or less
2. Installation measure :
 - a. Use a filter designed for N700E inverter
3. Wiring
 - a. Shielded wire (screened cable) is required for motor wiring, and the length must be Less than 20 meters.
 - b. The carrier frequency setting must be less than 5kHz to satisfy EMC requirements.
 - c. Separate the main circuit from the signal/process circuit wiring.
 - d. In case of remote operating with connector cable, the inverter does not conform to EMC
4. Environmental conditions – when using a filter, follow these guidelines:
 - a. Ambient air temperature : -10 - +40 °C
 - b. Humidity : 20 to 90% RH(non-condensing)
 - c. Vibration : 5.9 m/s² (0.6G) 10 – 55Hz (N700E-5.5 ~ 22kW)
 - d. Location : 1000 meters or less altitude, indoors(no corrosive gas or dust)

Conformity to the Low Voltage Directive (LVD)

The protective enclosure must conform to the Low Voltage Directive.
The inverter can conform to the LVD by mounting into a cabinet or by adding covers as follows.

1. Cabinet and Cover

The inverter must be installed into a cabinet which has the protection degree of Type IP2X.
In addition the top surfaces of cabinet are easily accessible shall meet at least the requirements of the protective Type IP4X, or which is constructed to prevent small objects from entering inverter.

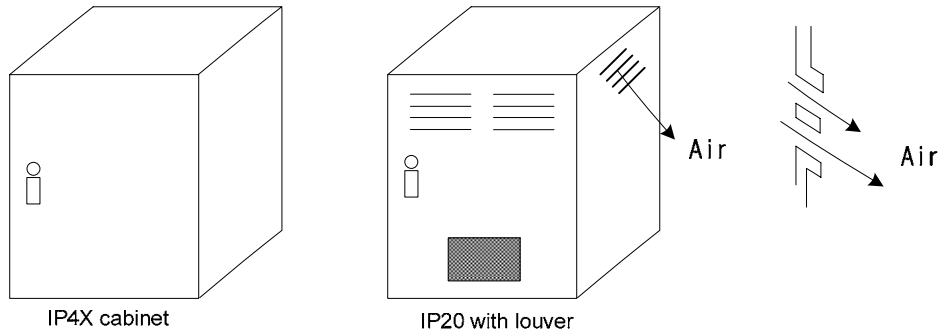

Fig 1. Inverter cabinet

UL Warnings and cautions Manual for N700E series

This auxiliary instruction manual should be delivered to the end user.

1. Wiring warning for Electrical Practice and Wire Specifications



WARNING : "Use Copper Conductor Only, 75 °C with a torque rating.



WARNING : "Suitable for use on a circuit capable or delivering not more than 5,000Arms symmetrical amperes, 240V maximum.



WARNING : "Suitable for use on a circuit capable or delivering not more than 5,000Arms symmetrical amperes, 480V maximum.

2. Tightening Torque and Wire Range



WARNING : Tightening torque and wire range for field wiring terminals are marked adjacent to the terminal or on the wiring diagram.

Model Name	Tightening Torque [lb-in]	Wire Range (AWG)	Ring terminal size Maximum wide [mm]
N700E-055LF	12.4	8	10.6
N700E-075LF	12.4	8	10.6
N700E-110LF	26.6	6	10.6
N700E-150LF	35.4	4	13
N700E-185LF	35.4	3	13
N700E-220LF	35.4	1	17
N700E-055HF	12.4	12	10.6
N700E-075HF	12.4	10	10.6
N700E-110HF	12.4	8	10.6
N700E-150HF	26.6	8	13
N700E-185HF	26.6	8	13
N700E-220HF	26.6	6	13

*Recommended ring terminal size (UL listed) for 055LF~110LF:Maximum wide 12mm

2. Fuse Size



WARNING : Distribution fuse size marking is included in the manual to indicate that the unit shall be connected with an UL Listed inverse time, rated 600V with the current ratings or an UL Listed fuse as shown in the table below.

Model Name	Fuse [A]
N700E-055LF	30
N700E-075LF	40
N700E-110LF	60
N700E-150LF	80
N700E-185LF	100
N700E-220LF	125
N700E-055HF	15
N700E-075HF	20
N700E-110HF	30
N700E-150HF	40
N700E-185HF	50
N700E-220HF	60

4. Others



WARNING : “Field wiring connection must be made by an UL Listed and CSA Certified closed-loop terminal connector sized for the wire gauge involved. Connector must be fixed using the crimp tool specified by the connector manufacturer.”, or equivalent wording included in the manual.

General Safety Information

DEFINITIONS AND SYMBOLS

A SAFETY INSTRUCTION (MESSAGE) INCLUDES A HAZARD ALERT SYMBOL AND A SIGNAL WORD, DANGER OR CAUTION. EACH SIGNAL WORD HAS THE FOLLOWING MEANING :

THIS SYMBOL IS THE "SAFETY ALERT SYMBOL." IT OCCURS WITH EITHER OF TWO SIGNAL WORDS : DANGER OR CAUTION, AS DESCRIBED BELOW.

 **DANGER** : INDICATES A POTENTIALLY HAZARDOUS SITUATION WHICH, IF NOT AVOIDED, CAN RESULT IN SERIOUS INJURY OR DEATH.

 **CAUTION** : INDICATES A POTENTIALLY HAZARDOUS SITUATION WHICH, IF NOT AVOIDED, CAN RESULT IN MINOR TO MODERATE INJURY, OR SERIOUS DAMAGE TO THE PRODUCT.

THE SITUATION DESCRIBED IN THE CAUTION MAY, IF NOT AVOIDED, LEAD TO SERIOUS RESULTS. IMPORTANT SAFETY MEASURES ARE DESCRIBED IN CAUTION (AS WELL AS DANGER), SO BE SURE TO OBSERVE THEM.

NOTE : INDICATES AN AREA OR SUBJECT OF SPECIAL MERIT, EMPHASIZING EITHER THE PRODUCT'S CAPABILITIES OR COMMON ERRORS DURING OPERATION OR MAINTENANCE.

General Safety Information

1. Installation

CAUTION

- Be sure to install the unit on flame resistant material such as metal. Otherwise, there is a danger of fire.
- Be sure not to place anything highly flammable in the vicinity. Otherwise, there is a danger of fire.
- Do not carry unit by top cover, always carry by supporting base of unit. There is a risk of falling and injury.
- Be sure not to let foreign matter enter inverter such as cut wire refuse, spatter from welding, iron refuse, wire, dust, etc. Otherwise, there is a danger of fire.
- Be sure to install inverter in a place which can bear the weight according to the specifications in the text. (Chapter 6. Specifications) Otherwise, it may fall and there is a danger of injury.
- Be sure to install the unit on a perpendicular wall which is not subject to vibration. Otherwise, the inverter may fall and cause injury to personnel.
- Be sure not to install and operate an inverter which is damaged or has parts which are missing. Otherwise, there is a danger of injury.
- Be sure to install the inverter in an area which is not exposed to direct sunlight and is well ventilated. Avoid environments which tend to be high in temperature, high in humidity or to have dew condensation, as well as places with dust, corrosive gas, explosive gas, highly flammable gas, grinding-fluid mist, salt damage, etc. Otherwise, there is a danger of fire.

General Safety Information

2. Wiring

WARNING

- Be sure to ground the unit.
Otherwise, there is a danger of electric shock and/or fire.
- Wiring work should be carried out by qualified electricians.
Otherwise, there is a danger of electric shock and/or fire.
- Implement wiring after checking that the power supply is off.
Otherwise, there is a danger of electric shock and/or fire.
- After installing the main body, carry out wiring.
Otherwise, there is a danger of electric shock and/or injury.
- Do not remove the rubber bushing where wiring connections are made.
Due to the possibility that a wire may be damaged, shorted or may have a ground fault with the edge of the wiring cover.

CAUTION

- Make sure that the input voltage is:
Three phase 200 to 240V 50/60Hz
Three phase 380 to 480V 50/60Hz
- Be sure not to single phase the input.
Otherwise, there is a danger of fire.
- Be sure not to connect AC power supply to the output terminals(U, V, W).
Otherwise, there is a danger of injury and/or fire and/or damage to unit.
- Be sure not to connect a resistor to the DC terminals(PD, P and N) directly.
Otherwise, there is a danger of fire and/or damage to unit.
- Be sure to install an earth leakage breaker or the fuse(s) which is(are) the same phase as the main power supply in the operation circuit.
Otherwise, there is a danger of fire and/or damage to unit.
- As for motor leads, earth leakage breakers, and electromagnetic contactors, be sure to use equivalent ones with the specified capacity(rated).
Otherwise, there is a danger of fire and/or damage to unit.
- Do not stop operation by switching off the electromagnetic contactors on the primary or secondary sides of the inverter.
Otherwise, there is a danger of injury and/or machine breakage.
- Fasten the screws to the specified torque. Check so that there is no loosening of screws.
Otherwise, there is a danger of fire and/or injury to personnel.

General Safety Information

3. Control and operation

WARNING

- While the inverter is energized, be sure not to touch the main terminal or to check the signal or add or remove wires and/or connectors.
Otherwise, there is a danger of electric shock.
- Be sure to turn on the power supply with the front case is closed.
While the inverter is energized, be sure not to open the front case.
Otherwise, there is a danger of electric shock.
- Be sure not to operate the switches with wet hands.
Otherwise, there is a danger of electric shock.
- While the inverter is energized, be sure not to touch the inverter terminals even while the unit is not running.
Otherwise, there is a danger of electric shock.
- If the retry mode is selected, it may suddenly restart during the trip stop.
Be sure not to approach the equipment. (Be sure to design the equipment so that personnel safety will be secured even if equipment restarts.)
Otherwise, there is a danger of injury.
- Be sure not to select retry mode for equipment running up and down or traversing because there is output free-running mode in term of retry.
Otherwise, there is a danger of injury and/or machine breakage.
- Even if the power supply is cut for a short period of time, the inverter may restart operation after the power supply is restored if the operation command is given.
If a restart may incur danger to personnel, be sure to make a circuit so that it will not restart after power recovery.
Otherwise, there is a danger of injury.
- The stop key is valid only when a function is on. Ensure that there is a hard wired emergency stop that is separate from the stop key of the inverter.
Otherwise, there is a danger of injury.
- With the operation command on, if the alarm reset is ordered, the inverter can restart suddenly. Be sure to set the alarm reset after checking the operation command is off.
Otherwise, there is a danger of injury.
- Be sure not to touch the inside of the energized inverter or to put a shorting bar into it.
Otherwise, there is a danger of electric shock and/or fire.

General Safety Information

CAUTION

- The cooling fins will have a high temperature. Be sure not to touch them. Otherwise, there is a danger of getting burned.
- Low to high speed operation of the inverter can be easily set. Be sure to operate it after checking the tolerance of the motor and machine. Otherwise, there is a danger of injury.
- Install an external breaking system if needed. Otherwise, there is a danger of injury.
- If a motor is operated at a frequency outside of the standard setting value (50Hz/60Hz), be sure to check the speeds of the motor and the equipment with each manufacturer, and after getting their consent, operate them. Otherwise, there is a danger of equipment breakage.
- Check the following before and during the test run.
 - Was the direction of the motor correct?
 - Did the inverter trip for on acceleration or deceleration?
 - Were the RPM and frequency motor correct?
 - Were there any abnormal motor vibrations or noises?
 Otherwise, there is a danger of machine breakage.

4. Maintenance, inspection and part replacement

WARNING

- After turning off the input power supply, do not perform the maintenance and inspection for at least 10 minutes. Otherwise, there is a danger of electric shock.
- Make sure that only qualified persons will perform maintenance, inspection and/or part replacement. (Before starting the work, remove metallic objects(wristwatch, bracelet, etc.) from a worker. (Be sure to use insulated tools.) Otherwise, there is a danger of electric shock and/or injury.

5. Others

WARNING

- Never modify the unit. Otherwise, there is a danger of electric shock and/or injury.

CAUTION

- Heavy object(over 15kg). To avoid muscle strain or back injury, use lifting aids and proper lifting techniques when removing or replacing.

CONTENTS

1. GENERAL DESCRIPTION	1-1
1.1 Inspection upon Unpacking	1-1
1.1.1 Inspection of the unit.....	1-1
1.1.2 Instruction manual	1-1
1.2 Questions and Warranty of the Unit	1-2
1.2.1 Questions on Unit.....	1-2
1.2.2 Warranty for the unit	1-2
1.3 Appearance	1-3
2. Installation and Wiring	2-1
2.1 Installation	2-1
2.1.1 Installation.....	2-2
2.2 Wiring.....	2-4
2.2.1 Terminal Connection Diagram (sink type).....	2-5
2.2.2 Main circuit wiring	2-7
2.2.3 Terminal connection diagram.....	2-12
3. Operation	3-1
3.1 Operating	3-3
3.1.1 Operation setting and a frequency setting by the terminal control	3-3
3.1.2 Operation setting and frequency setting with the digital operator.....	3-3
3.1.3 Operation setting and frequency setting from both the digital operator and the terminal operator	3-3
3.2 Test Run.....	3-4
3.2.1 To input the operation setting and the frequency setting from the terminal control.....	3-4
3.2.2 Operation setting and the frequency setting from the digital operator	3-5
4. Parameter Code List	4-1
4.1 About Digital Operator.....	4-1
4.1.1 Name and contents of each part of Standard-type digital operator	4-1
4.2 Function List.....	4-4
4.2.1 Monitor Mode (d-group)	4-4
4.2.2 Trip & Warning monitor mode (d-group)	4-5
4.2.3 Basic Function Mode	4-6
4.2.4 Expanded Function Mode of A Group	4-7
4.2.5 Expanded function mode of B group.....	4-14
4.2.6 Expanded Function Mode of C Group.....	4-17
4.2.7 Expanded function mode of S group	4-20
4.2.8 Expanded Function mode of H Group.....	4-23
5. Using intelligent terminals	5-1
5.1 Intelligent terminal lists	5-1
5.2 Monitor terminal function	5-3
5.3 Intelligent Input Terminal Function	5-4
5.4 Using Intelligent output terminals.....	5-17
5.5 Alarm Terminal Function.....	5-22
5.6 Configuring the Inverter of Multiple Motors.....	5-23
5.7 Sensorless Vector Control.....	5-24
5.8 Auto-tuning.....	5-25
6. Protective function	6-1

7. Troubleshooting Tips	7-1
8. Maintenance and Inspection	8-1
8.1 General Precautions and Notes	8-1
8.2 Inspection Items	8-1
8.3 General Inverter Electrical Measurements	8-4
9. RS485 Communication	9-1
10. Specification	10-1
10.1 Standard specification list	10-1
10.2 Dimension	10-4

1. GENERAL DESCRIPTION

1.1 Inspection upon Unpacking

1.1.1 Inspection of the unit

Please open the package, remove the inverter, please check the following items.

If you discover any unknown parts or the unit is damaged, please contact HYUNDAI.

- (1) Make sure that the package contains one operation manual for the inverter.
- (2) Make sure that there was no damage (broken parts in the body) during transportation of the unit.
- (3) Make sure that the product is the one you ordered by checking the label specification.

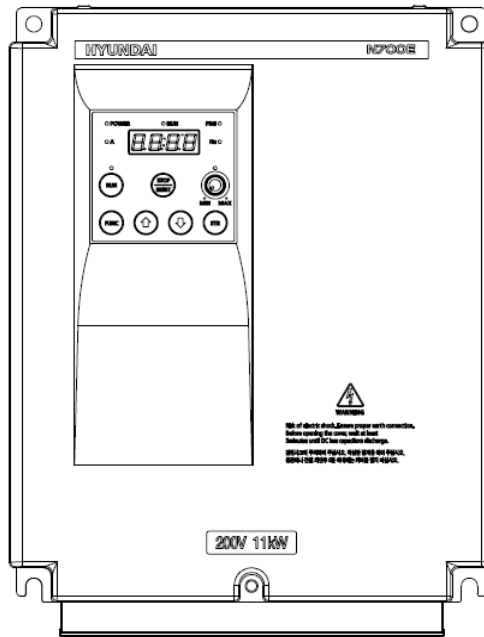

Fig1-1 Outlook of N700E Inverter

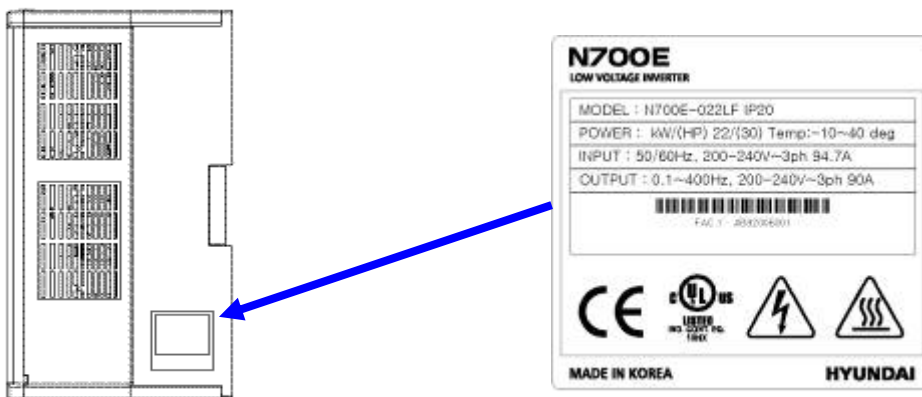

Fig1-2 Contents of Specification label

1.1.2 Instruction manual

This instruction manual is the manual for the N700E inverters.

Before operation of the inverter, read the manual carefully. After reading this manual, keep it on hand for future reference

1.2 Questions and Warranty of the Unit

1.2.1 Questions on Unit

- If you have any questions regarding damage to the unit, unknown parts or for general inquiries, please contact your LOCAL HYUNDAI BRANCH with the following information.

- (1) Inverter Model
- (4) Production Number (Serial No.)
- (5) Date of purchase
- (6) Reason for Calling
 - ① Damaged part and its condition etc.
 - ② Unknown parts and their contents etc

1.2.2 Warranty for the unit

- (1) The warranty period of the unit is one year after the purchase date. However the warranty will be void if the fault is due to;
 - ③ Incorrect use as directed in this manual, or attempted repair by unauthorized personnel.
 - ④ Any damage sustained other than from transportation (Which should be reported immediately).
 - ⑤ Using the unit beyond the limits of the specifications.
 - ⑥ Natural Disasters : Earthquakes, Lightning, etc
- (7) The warranty is for the inverter only, any damage caused to other equipment by malfunction of the inverter is not covered by the warranty.
- (8) Any examination or repair after the warranty period (one-year) is not covered. And within the warranty period any repair and examination which results in information showing the fault was caused by any of the items mentioned above, the repair and examination costs are not covered. If you have any questions regarding the warranty, please contact either your Local HYUNDAI Branch.

1.3 Appearance



Fig1-3 Appearance from the front

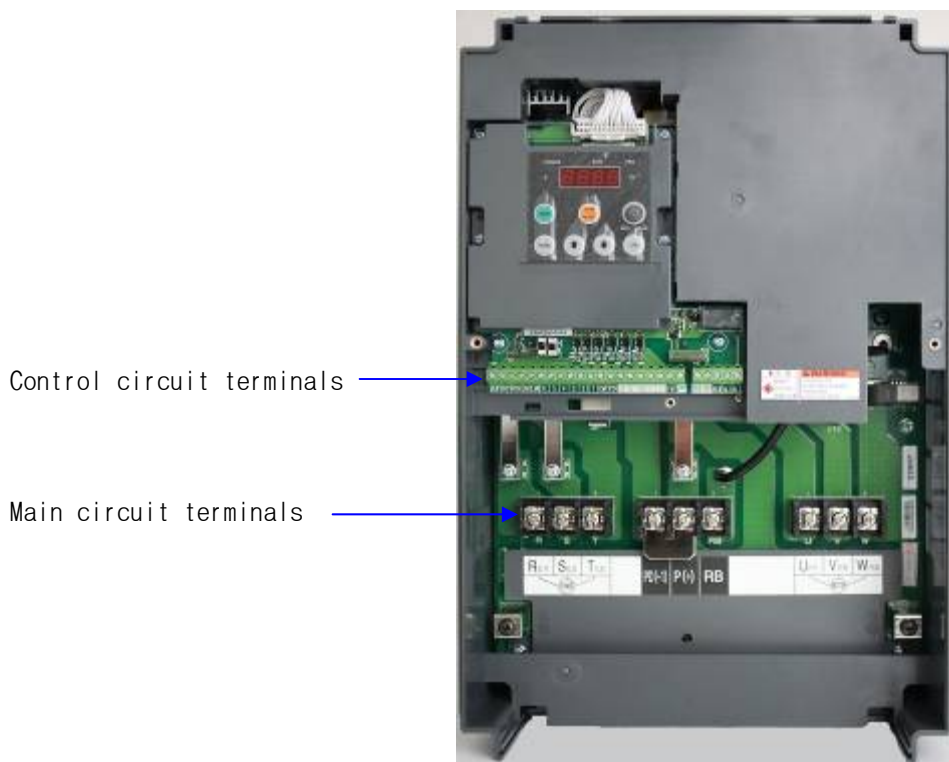

Fig1-4 Front cover removed

2. Installation and Wiring

2.1 Installation

 CAUTION
--

- Be sure to install the unit on flame resistant material such as metal.
Otherwise, there is a danger of fire.
- Be sure not to place anything flammable in the vicinity.
Otherwise, there is a danger of fire.
- Do not carry the unit by the top cover, always carry by supporting the base of unit.
There is a risk of falling and injury.
- Be sure not to let foreign matter enter such as cut wire refuse, spatter from welding, iron refuse, wire, dust, etc.
Otherwise, there is a danger of fire.
- Be sure to install the inverter in a place which can bear the weight according to the specifications in the text.
Otherwise, it may fall and result in possible injury.
- Be sure to install the unit on a perpendicular wall which is not subject to vibration.
Otherwise, the inverter may fall and cause injury to personnel.
- Be sure not to install and operate an inverter which is damaged or parts of which are missing.
Otherwise, there is a danger of injury.
- Be sure to install the inverter in an area which is not exposed to direct sunlight and is well ventilated. Avoid environments which tend to be high in temperature, high in humidity or to have dew condensation, as well as places with dust, corrosive gas, explosive gas, inflammable gas, grinding-fluid mist, salt damage, etc.
Otherwise, there is a danger of fire.

2.1.1 Installation

(1) Transportation

This inverter has plastic parts. So handle with care.

Do not over tighten the wall mounting fixings as the mountings may crack, causing is a risk of falling.

Do not install or operate the inverter if there appears to be damaged or parts missing.

(2) Surface for the mounting of inverter

The temperature of the inverter heatsink can rise very high.

The surface, to which the inverter will be mounted, must be made of a non-flammable material(i.e steel) due to the possible risk of fire. Attention should also be made to the air gap surrounding the inverter.

Especially, when there is a heat source such as a breaking resistor or reactor.

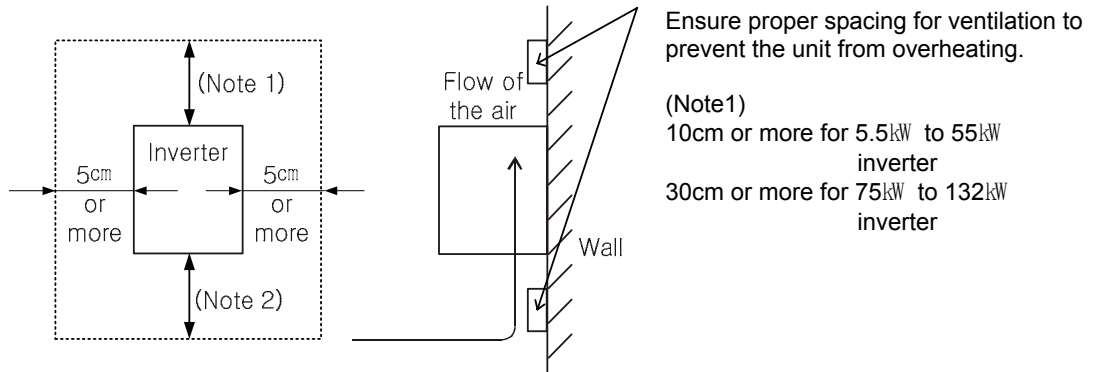

Fig 2- 1 Surface for the mounting of inv

(3) Operating Environment-Ambient Temperature

The ambient temperature surrounding the inverter should not exceed the allowable temperature range (14 to 122°F, -10 to 50°C).

The temperature should be measured in the air gap surrounding the inverter, shown in the diagram above. If the temperature exceeds the allowable temperature, component life will become shortened especially in the case of the Capacitors.

(4) Operating Environment-Humidity

The humidity surrounding the inverter should be within the limit of the allowable percentage range (20% to 90% / RH).

Under no circumstances should the inverter be in an environment where there is the possibility of moisture entering the inverter.

Also avoid having the inverter mounted in a place that is exposed to the direct sunlight.

(5) Operating Environment-Air

Install the inverter in a place free from dust, corrosive gas, explosive gas, combustible gas, mist of coolant and sea damage.

(6) Mounting Position

Mount the inverter in a vertical position using screws or bolts. The mounting surface should also be free from vibration and can easily hold the weight of the inverter.

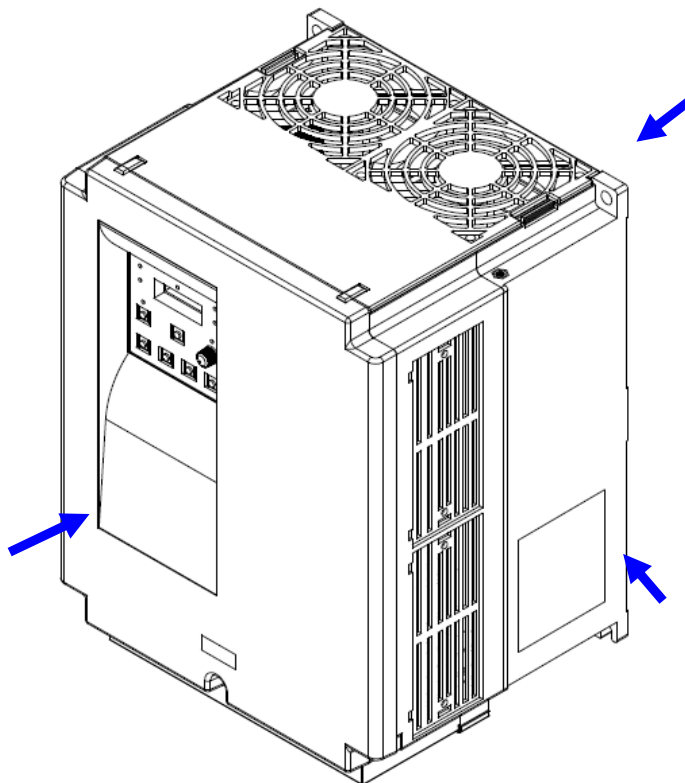

Fig 2-2 Mounting Position

(7) Ventilation within an Enclosure

If you are installing one or more inverters in an enclosure a ventilation fan should be installed. Below is a guide to the positioning of the fan to take the airflow into consideration. The positioning of inverter, cooling fans and air intake is very important.

If these positions are wrong, airflow around the inverter decreases and the temperature surrounding the inverter will rise. So please make sure that the temperature around is within the limit of the allowable range.

(8) External cooling of inverter

It is possible to install the inverter so that the heatsink is outside of the back of the enclosure. This method has two advantages, the cooling of the inverter is greatly increased and the size of the enclosure will be smaller.

To install it with the heatsink outside of the enclosure, a metal fitting option is required to ensure heat transfer. Do not install in a place where water, oil, mist, flour, and/or dust etc. can come in contact with the inverter as there are cooling fans fitted to the heatsink.

2.2 Wiring

WARNING

- Be sure to ground the unit.
Otherwise, there is a danger of electric shock and/or fire.
- Wiring work should be carried out by qualified electricians.
Otherwise, there is a danger of electric shock and/or fire.
- Implement wiring after checking that the power supply is off.
Otherwise, there is a danger of electric shock and/of fire.
- After mounting the inverter, carry out wiring.
Otherwise, there is a danger of electric shock and/or injury.
- Do not remove the rubber bushings where wiring connections are made.
(5.5 to 22kW) Due to the possibility that a wire may be damaged, shorted or may have a ground fault with the edge of the wiring cover.

CAUTION

- Make sure that the input voltage is:
Three phase 200 to 240V 50/60Hz(Model : N700E-055LF thru 220LF)
Three phase 380 to 480V 50/60Hz(Model : N700E-055HF thru 220HF)
- Be sure not to power a three-phase-only inverter with single phase power.
Otherwise, there is a danger of fire.
- Be sure not to connect AC power supply to the output terminals(U, V, W).
Otherwise, there is a danger of injury and/or fire and/or damage to unit.
- Be sure not to connect a resistor to the DC terminals(PD, P) directly.
Otherwise, there is a danger of fire and/or damage to unit..
- Be sure to set a earth leakage breaker or the fuse(s) which is(are) the same phase as the main power supply in the operation circuit.
Otherwise, there is a danger of fire and/or damage to unit..
- As for motor leads, earth leakage breakers, and electromagnetic contactors, be sure to use equivalent ones with the specified capacity(rated).
Otherwise, there is a danger of fire and/or damage to unit..
- Do not stop operation by switching off the electromagnetic contactors on the primary or secondary sides of the inverter.
Otherwise, there is a danger of injury and/or machine breakage.
- Fasten the screws to the specified torque. Check so that there is no loosening of screws.
Otherwise, there is a danger of fire and/or damage to unit..

2.2.1 Terminal Connection Diagram (sink type)

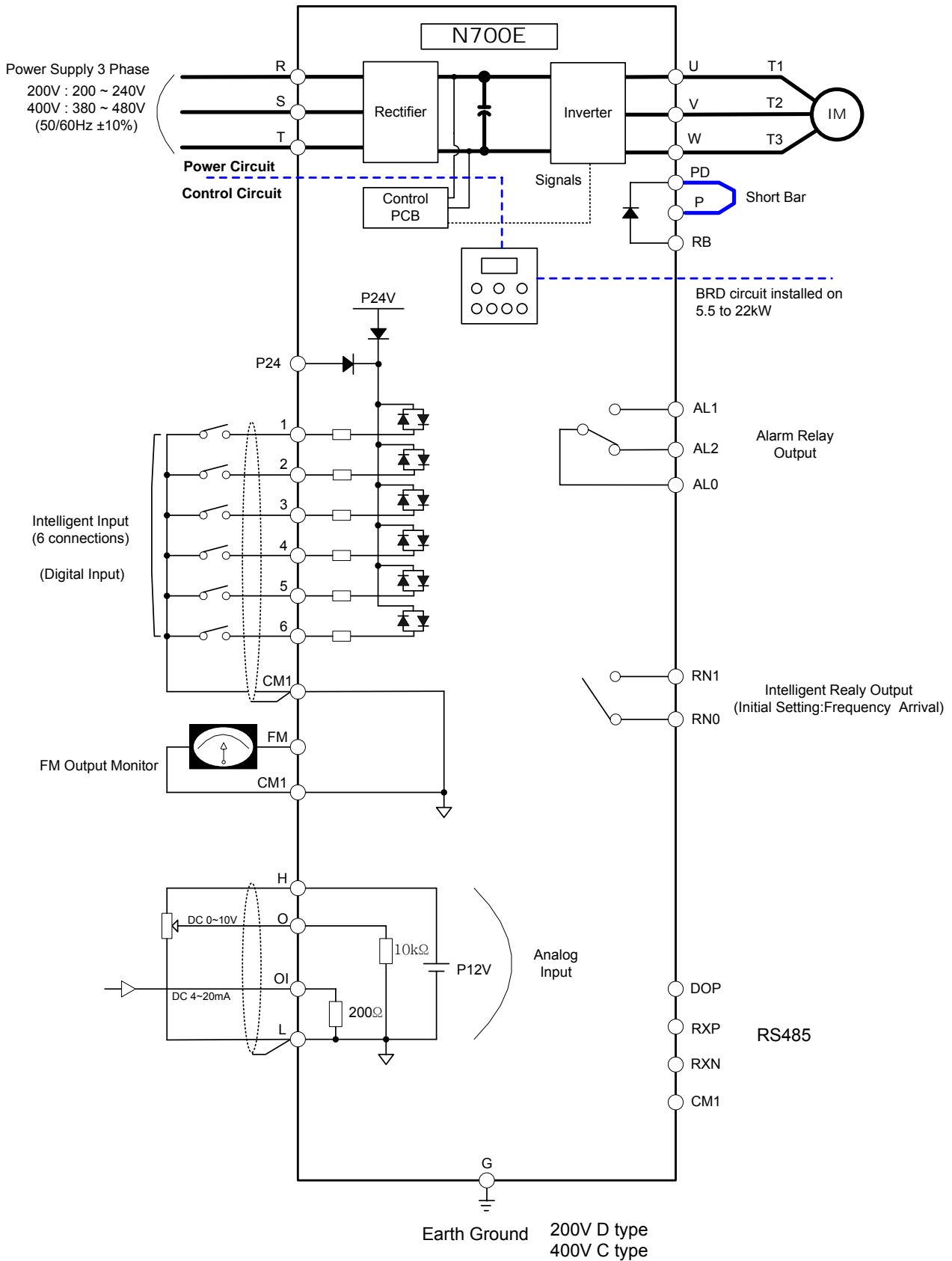

Fig.2-3 Terminal Connection Diagram (sink type)

(1) Explanation of main circuit Terminals

Symbol	Terminal Name	Explanation of contents
R,S,T (L1,L2,L3)	Main power	Connect alternating power supply. When using regenerative converter and RG series, don't connect.
U,V,W (T1,T2,T3)	Inverter output	Connect three-phase motor.
PD,P (+1,+)	D.C.reactior	Remove the short bar between PD and P, connect optional Power factor reactor (DCL-XX).
P, RB (+, B+)	External braking resistor	Connect optional External braking resistor. (Please install the optional External braking resistor for 5.5~22kW model.)
G	Inverter earth terminals	Grounding terminal.

Table 2-1 Explanation of main circuit terminals

(2) Control circuit Terminals

Signal	Terminal Symbol	Terminal name	Terminal function
Input signal	P24	Interface power	24VDC ±10%, 35mA
	6 (RS)	Intelligent Input Terminal	Contact input : Close : ON (operating) Open : OFF (stop) Minimum ON TIME :12ms or more
	5 (AT)	Forward run command(FW), Reverse run command(RV),	
	4 (CF2)	multi-speed commands1-4(CF1-4), 2-stage accel/decel (2CH),	
	3 (CF1)	Reset(RS), Second control function setting(SET),	
	2 (RV)	Terminal software lock(SFT),	
	1 (FW)	Unattended start protection(USP) ^(Note2) , Current input selection(AT), Jogging operation(JG), External trip(EXT)	
	CM1	Common terminal for input or monitor signal	
Monitor signal	FM	Analog Monitor (Frequency, Current, Voltage)	Analog Frequency Meter
Frequency command signal	H	Frequency power	10VDC
	O	Frequency command power terminal (voltage)	0-10VDC, Input Impedance 10kΩ
	OI	Frequency command Terminal (current)	4-20mA, Input Impedance 210Ω
	L	Analog power common	
Output signal	RN0 RN1	Intelligent output terminal: Run status signal(RUN), Frequency arrival signal(FA1), Set frequency arrival signal(FA2), Overload advance notice signal(OL), PID error deviation signal(OD), Alarm signal(AL)	Contact rating: AC 250V 2.5A (resistor load) 0.2A (inductor load) DC 30V 3.0A (resistor load) 0.7A (inductor load)
TRIP ALARM Output signal	AL0 AL1 AL2	Alarm output signals : at normal status, power off : AL0-AL2 (closed) at abnormal status : AL0-AL1(closed) 	Contact rating: AC 250V 2.5A (resistor load) 0.2A (inductor load) DC 30V 3.0A (resistor load) 0.7A (inductor load)

Table2-2 Control circuit Terminals

2.2.2 Main circuit wiring

(1) Warning on wiring

When carrying out work on the inverter wiring make sure to wait for at least ten minutes before you remove the cover. Be sure to verify that the charge lamp is not illuminated.

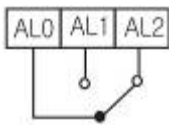
A final check should always be made with a voltage meter.

After removing the power supply, there is a time delay before the capacitors will dissipate their charge.

① Main power terminals (R, S and T)

- Connect the main power terminals (R, S and T) to the power supply through an electromagnetic contactor or an earth-leakage breaker.
N700 recommends connecting the electromagnetic contactor to the main power terminals, because when the protective function of the inverter operates, it isolates the power supply and prevents the spread of damage and accident.
- This unit is for a three-phase power supply. Be sure not to power a three-phase only inverter with single phase power. Otherwise, there is the possibility of damage to the inverter and the danger of fire.
- If you require a single phase power supply unit, please contact your local HYUNDAI Branch.
- The inverter enters into the following condition at the occurrence of open phase if it is selected open phase protection is valid :
 - R phase, S phase or T phase, open phase condition:
It becomes single-phase operation condition. Trip operation, such as a deficiency voltage or over current, may occur.
- Don't use it under open phase condition. A converter module may be damaged as a result of the following conditions. Use caution when
 - an unbalance of the power supply voltage is more than 3%
 - Power supply capacity is more than 10 times of the capacity of inverter and case beyond 500kVA.
 - A drastic change in the power supply(Example) Turning on/off of the power supply should not be done more than three times in one minute. It has the possibility of damaging the inverter.

② Inverter output terminals (U, V, and W)

- Using a heavier gauge wire can prevent the voltage drop.
Particularly when outputting low frequencies, the torque of the motor will be reduced by the voltage drop of the wire.
Do not install power factor correction capacitors or a surge absorber to the output.
The inverter will trip or sustain damage to the capacitors or the surge absorber.
- In the case of the cable length being more than 65 feet, it is possible that a surge voltage will be generated and damage to the motor is caused by the floating capacity or the inductance in the wire. When an EMC filter is to be installed, please contact your local HYUNDAI branch.
- In the case of two or more motors, install a thermal relay to each motor.
- Make the RC value of the thermal relay the value of 1.1 times of motor rated electric current.

③ Direct current reactor (DCL) connection terminals (PD, P)

- These are the terminals to connect the current reactor DCL (optional) to help improve the power factor.
- The short bar is connected to the terminals when shipped from the factory, if you are to connect a DCL you will need to disconnect the short bar first.
- When you do not use a DCL, do not disconnect the short bar.

④ External braking resistor connection terminals (P, RB)

- The regenerative braking circuit (BRD) is built-in as standard
- When braking is required, install an external-braking resistor to these terminals.
- The cable length should be less than 16 feet, and twist the two connecting wires to reduce inductance.

Do not connect any other device other than the external braking resistor to these terminals.

- When installing an external braking resistor make sure that the resistance is correctly rated to limit the current drawn through the BRD.
- ⑤ Earth Ground (G)
- Make sure that you securely ground the inverter and motor for prevention of electric shock.
 - The inverter and motor must be connected to an appropriate safety earth ground and follow all local electrical codes.
 - In case connecting 2 or more inverters, use caution not to use a loop which can cause some malfunction of the inverter.

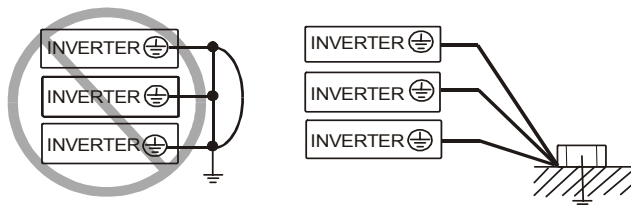

Fig. 2- 4 Earth Ground (G)

(2) Wiring of main circuit terminals

The wiring of main circuit terminals for the inverter are in the following pictures.

Wiring of terminals	Corresponding type	Screw Size	Width (mm)
	N700E-055LF N700E-075LF N700E-055HF N700E-075HF N700E-110HF	M4	10.6
	N700E-110LF	M5	13
	N700E-150LF N700E-150HF N700E-185HF N700E-220HF	M5	13
	N700E-185LF N700E-220LF	M6	17

Table 2-3 Wiring of main circuit terminals

(3) Applicable Tools

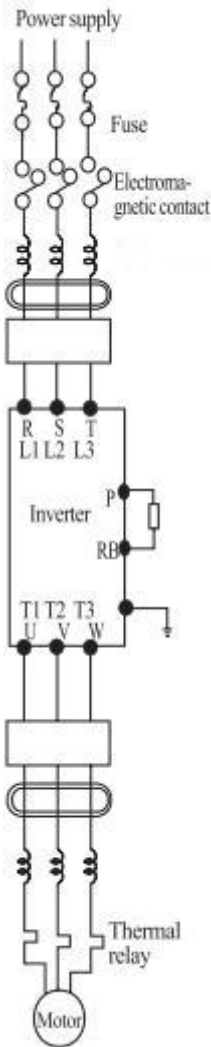

Note1 : The applicable equipment is for HYUNDAI standard four pole squirrel cage motor.

Note2 : Be sure to consider the capacity of the circuit breaker to be used.

Note3 : Be sure to use larger wire for power lines if the distance exceeds 20m.

Note4 : Be sure to use an grounding wire same size of power line or similar.

Note5 : Use 0.75mm² for AL relay and RN relay.

Separate by the sum(wiring distance from inverter to power supply, from inverter to motor for the sensitive current of leakage breaker (ELB)

Wiring distance	Sensitive Current(mA)
100m and less	50
300m and less	100

Table2-4 Enssitive current according to wiring distance

Note6 : When using CV line and wiring by rigid metal conduit, leak flows.

Note7 : IV line is high dielectric constant. SO the current increase 8 times.

Therefore, use the sensitive current 8 times as large as that of the left list. And if the distance of wire is over 100m, use CV line.

Name		Function
(1)	Input reactor (harmonic control, electrical coordination, power-factor improvement)	This part is used when the unbalance voltage rate is 3% or more and power supply is 500 kVA or more, and there is a rapid change in the power supply. It also improves the power factor.
(2)	Radio noise filter (zero-phase reactor)	Using the inverter may cause noise on the peripheral radio through the power lines. This part reduces noise.
(3)	Noise filter for Inverter	This part reduces common noise generated between the power supply and the ground, as well as normal noise. Put it in the primary side of inverter.
(4)	Input radio noise filter (capacitor filter)	This part reduces radiation noise emitted from wire at the input.
(5)	Direct reactor	This part control harmonic from inverter.
(6)	Breaking resistor Regenerative breaking unit	This part is used for applications that need to increase the brake torque of the inverter or to frequently turn on and off and to run high inertia load.
(7)	Output noise filter	This part reduces radiation noise emitted from wire by setting between inverter and motor. And it reduces wave fault to radio and TV, it is used for preventing malfunction of sensor and measuring instruments.
(8)	Output alternation reactor Reducing vibration, thermal Relay, preventing Misapplication	Running motors with the inverter generates vibration greater than that with commercial power supply. This part installed between the inverter and motor reduces torque ripple. When the cable length between the inverter and motor is long (10m or more), a countermeasure for a malfunction of the thermal relay, by harmonic due to switching on inverter is taken by inserting reactor. There is the way to use current sensor in stead of thermal relay.
(9)	LCR filter	Sine-wave filter at the output.

Table 2-5 Optional accessories for improved performance

(4) Common applicable tools

Class	Motor Output kW(HP)	Inverter model	Power lines R,S,T U,V,W, P,PD,N (mm ²)	External resistor between P and RB (mm ²)	Screw size of Terminal	Torque (N•m)	Applicable Tools		
							Leak breaker (MCCB)		Electromagnetic Controller (MC)
200V Class	5.5	N700E-055LF	More than 6	6	M4	1.2	HBS60N	50A	HiMC32
	7.5	N700E-075LF	More than 10	6	M4	1.2	HBS60N	50A	HiMC32
	11	N700E-110LF	More than 16	6	M5	3.0	HBS100N	75A	HiMC50
	15	N700E-150LF	More than 25	16	M5	3.0	HBS100N	100A	HiMC65
	18.5	N700E-185LF	More than 30	16	M6	4.5	HBS225N	150A	HiMC80
	22	N700E-220LF	More than 35	16	M6	4.5	HBS225N	150A	HiMC110
400V Class	5.5	N700E-055HF	More than 4	4	M4	1.2	HBS30N	30A	HiMC18
	7.5	N700E-075HF	More than 4	4	M4	1.2	HBS30N	30A	HiMC18
	11	N700E-110HF	More than 6	6	M4	1.2	HBS60N	50A	HiMC32
	15	N700E-150HF	More than 10	10	M5	3.0	HBS100N	50A	HiMC40
	18.5	N700E-185HF	More than 16	10	M5	3.0	HBS100N	75A	HiMC40
	22	N700E-220HF	More than 25	10	M5	3.0	HBS100N	75A	HiMC50

Table 2-6 Common applicable tools

2.2.3 Terminal connection diagram

(1) Terminal connection diagram

- ① The control circuit terminal of inverters is connected with the control board in unit.

DO	RX	RX	CM	CM	6	5	4	3	2	1	CM	P2	H	O	O	L	L	F	CM	RN	RN	AL	AL	AL
P	P	N	1	1							1	4						M	1	0	1	0	1	2

Fig 2-4 Terminal connection diagram

(2) Wiring

- ① Both the CM1 and L terminals are insulated to both the common terminal of the input and output signals. Do not short or connect to ground these common terminals.
- ② Use twisted screened cable, for the input and output wires of the control circuit terminals. Connect the screened cable to the common terminal.
- ③ Limit the connection wires to 65 feet.
- ④ Separate the control circuit wiring from the main power and relay control wiring.

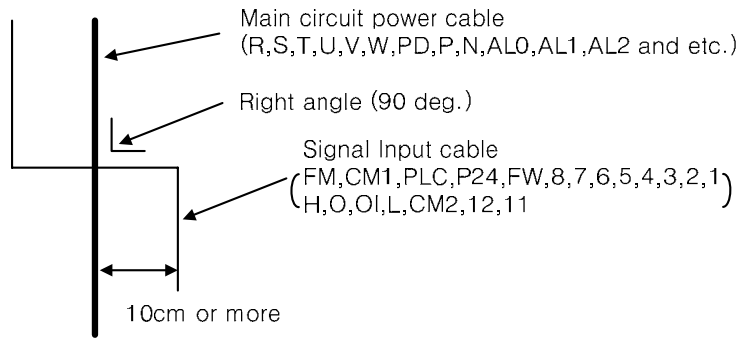

- ⑤ When using relays for the FW terminal or an intelligent input terminal use a control relay that is designed to work with 24Vdc.
- ⑥ When a relay is used as an intelligent output, connect a diode for surge protection parallel to the relay coil.
- ⑦ Do not short the analog voltage terminals H and L or the internal power terminals PV24 and all CM1's. Otherwise there is risk of Inverter damage.
- ⑧ When connecting a thermistor to the TH and all CM1's terminal, twist the thermistor cables and separate them from the rest. Limit the connection wires to 65 feet

- (3) Change of input logic type
 - Selection switch
 - ① SINK/SOURCE TYPE
 - J3 : SINK/SOURCE TYPE selection switch
 - J4 : selection switch for internal/external 24V power supply
 - ② The connection to the input programmable logic controller

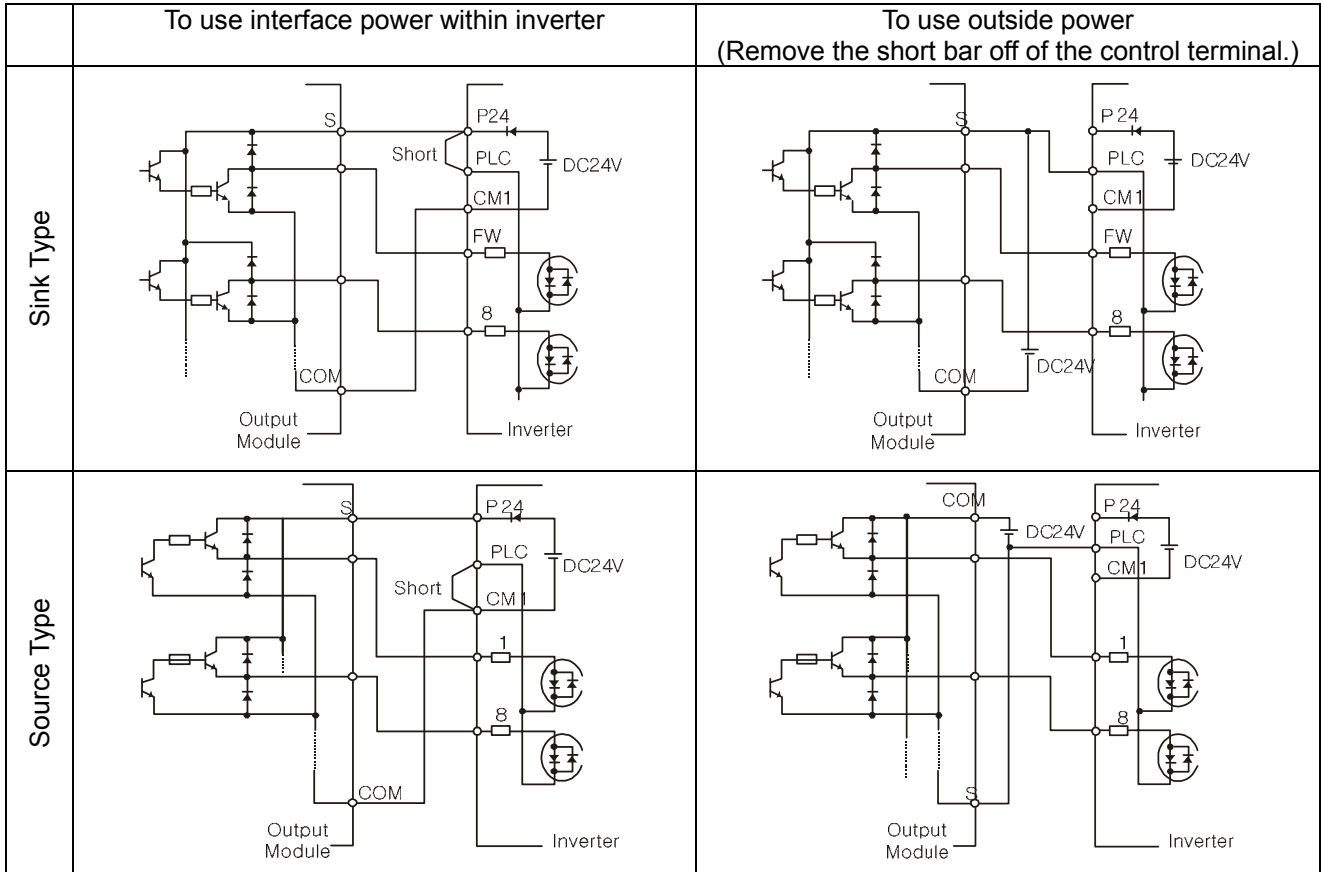

Fig 2-6 Input terminal and PLC connection

- (3) The connection to the output programmable logic controller (sequencer)

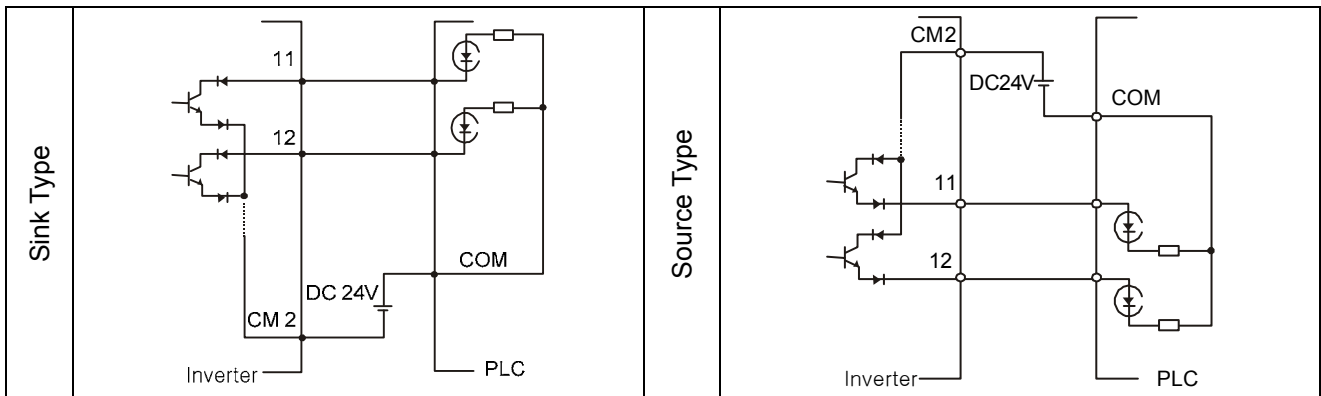

Fig 2-7 Output terminal and PLC connection

3. Operation

WARNING

- Be sure not to touch the main terminal or to check the signal add or remove wires and/or connectors.
Otherwise, there is a danger of electric shock.
- Be sure not to turn the input power supply on until after front case is closed.
While the inverter is energized, be sure not to remove the front cover.
Otherwise, there is a danger of electric shock.
- Be sure not to operate the switches with wet hands.
Otherwise, there is a danger of electric shock.
- While the inverter is energized, be sure not to touch the inverter terminals even while the unit is not running.
Otherwise, there is a danger of electric shock.
- If the retry mode is selected, it may suddenly restart during the trip stop.
Be sure not to approach the equipment.(Be sure to design the equipment so that personnel safety will be secured even if equipment restarts.)
Otherwise, there is a danger of injury.
- Be sure not to select retry mode for up and down equipment or traveling equipment, because there is an output free-running mode in term of retry.
Otherwise, there is a danger of injury and/or machine breakage
- Even if the power supply is cut for a short period of time, the inverter may restart operation after the power supply is restored if the operation command is given.
If a restart may incur danger to personnel, be sure to make a circuit so that it will not restart after power recovery.
Otherwise, there is a danger of injury.
- The stop key is valid only when a function is on. Ensure that there is a hard wired emergency stop that is separate from the stop key of the inverter.
Otherwise, there is a danger of injury.
- With the operation command on, if the alarm reset is ordered, the inverter can restart suddenly. Be sure to set the alarm reset after checking the operation command is off.
Otherwise, there is a danger of injury.
- Be sure not to touch the inside of the energized inverter or to put a bar into it.
Otherwise, there is a danger of electric shock and/or fire.

 **CAUTION**

- The cooling fins will have high temperature. Be sure not to touch them. Otherwise, there is a danger of getting burned.
- Low to high speed operation of the inverter can be easily set. Be sure to operate it after checking the tolerance of the motor and machine. Otherwise, there is a danger of injury.
- Install an external breaking system if needed. Otherwise, there is a danger of injury.
- If a motor is operated at a frequency higher than standard setting value(50Hz / 60Hz), be sure to check the speeds of the motor and the machine from their manufacturers. After getting their consent, operate them. Otherwise, there is a danger of machine breakage.

3.1 Operating

This inverter requires two different signals in order for the inverter to operate correctly. The inverter requires both an operation setting and a frequency setting signal.

The following indicates the details of each method of operation and necessary instructions for operation.

3.1.1 Operation setting and a frequency setting by the terminal control

- (1) This is the method which controls the inverter by connecting the control circuit terminals with signals from the outside(the frequency setting, the starting switch etc.).
- (2) The operation is started when the operation setting (FW, REV) is turned ON while the input power is turned ON.

(Note) The methods of setting the frequency with the terminal are the voltage setting and the current setting. Both are selective. The control circuit terminal list shows necessary things for each setting.

- ① The operation setting : switch, relay, etc.
- ② The frequency setting: signals from volume or external (DC 0~10V, DC 0~±10V, 4~20mA etc.)

3.1.2 Operation setting and frequency setting with the digital operator.

- (1) This is the method of operation from the digital operator, which is supplied with the inverter as standard, or the optional remote operator keypad (OPE. KEYPAD) and volume (OPE. VOL).
- (2) When the inverter is being controlled by digital operator, the terminals (FW, REV) are not available. Frequency can be also controlled by digital operator.

3.1.3 Operation setting and frequency setting from both the digital operator and the terminal operator

- (1) This is the method of inverter operating from both of the above two operating methods.
- (2) The operation setting and the frequency setting can be done through the digital operator and the terminal operator..

3.2 Test Run

This is an example of a common connection. Please refer to 4.1 Digital Operator, for the detailed use of the digital operator.

3.2.1 To input the operation setting and the frequency setting from the terminal control

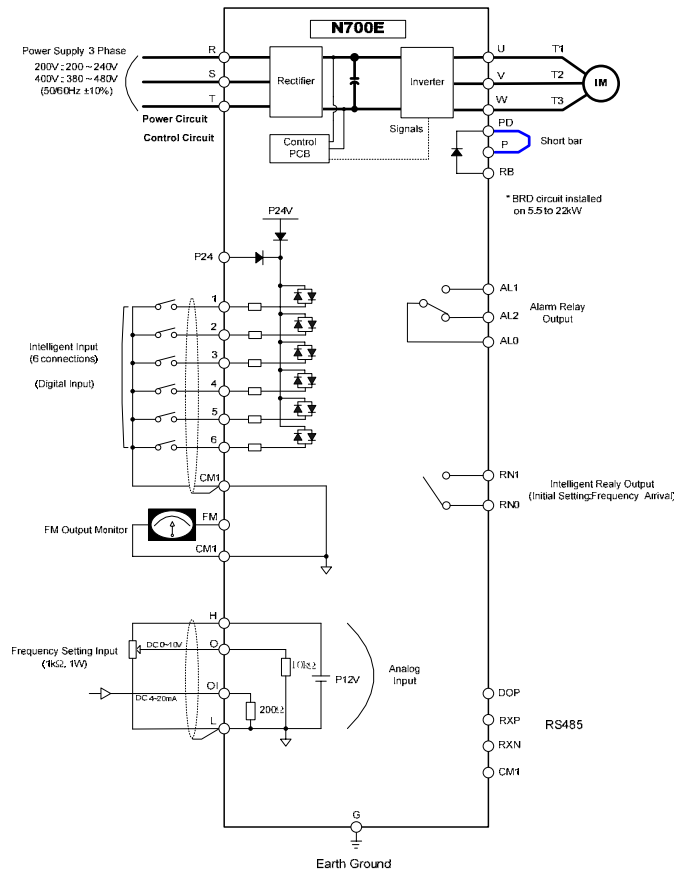

Fig 3-1 Setting diagram from the terminal control

(Procedure)

- (1) Please make sure that the connections are secured correctly.
- (2) Turn the MCCB on to supply power to the inverter.
(The LED "POWER" on the operator should illuminate)
- (3) Set the terminal with the frequency setting selection.
Set A01 as the indication code, press the **FUNC** key once. (Code values are shown)
Set 1(Terminal) with **UP/DOWN** key, press the **STR** key once to set the operation setting for the operator.(Indication code turns back to A01.)
- (4) Set terminal with the operation setting selection.
Set A02 as indication code, press the **FUNC** key once.
Set 1(terminal) with the **UP/DOWN** key, press the **STR** key once to set the operation setting for the operator.(Indication code turns back to A02.)
- (5) Set Monitor mode
When monitoring the output frequency, set indication code to d001, and press the **FUNC** key.
Or when monitoring the operation direction, set indication code to d04, and press the **FUNC** key.
- (6) Input starting operation setting.
Turn ON between [FW] and [CM1] of terminal.
Apply voltage [O] and [L] of terminal to start operation.
- (7) Input ending operation setting.
Turn OFF between [FW] and [CM1] to slowly stop.

3.2.2 Operation setting and the frequency setting from the digital operator

(Remote operator is also same use.)

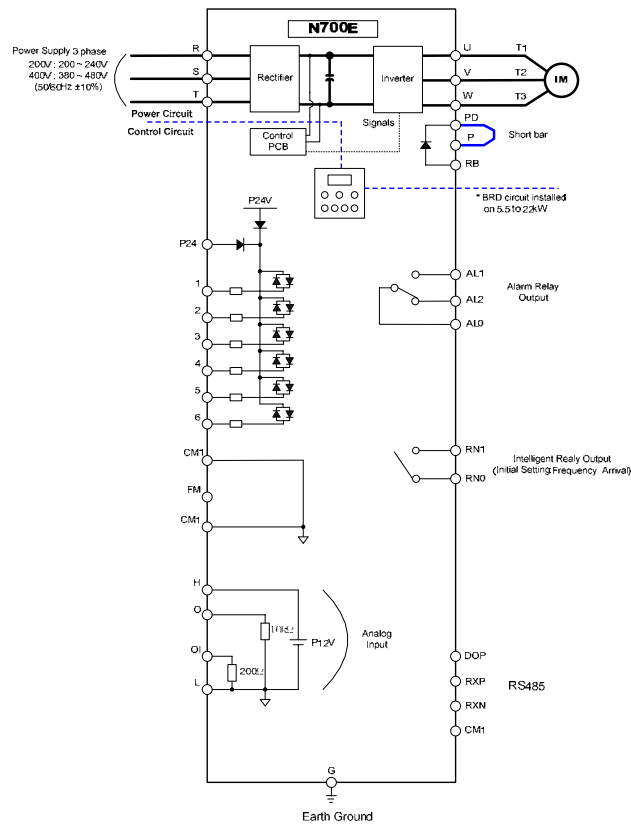

Fig 3-2 Setting diagram from the digital operator

(Procedure)

- (1) Please make sure that connection is right.
- (2) Turn the MCCB on to supply power to the inverter.
(The LED "POWER" on the operator should illuminate)
- (3) Set the operator with the frequency setting selection.
 - ① Set A01 as indication code, press the **FUNC** key once.
(Code values are shown)
 - ② Set 2(OPE KEYPAD) with **UP/DOWN** key, press the **STR** key once to set the operation setting for the operator. (Indication code turns back to A01.) [Setting method by OPE-N7]
- (4) Set the operator with the operation setting selection.
Set A02 as the indication code, press the **FUNC** key once.
Set 2(OPE) with **UP/DOWN** key, press the **STR** key once to set the operation setting for the operator. (Indication code turns back to A02.)
- (5) Set the output frequency
 - ① Set F001 as indication code, by pressing the **FUNC** key once. (Code values are shown.)
 - ② Set to the desired output frequency with the **UP/DOWN** key, press the **STR** key once to store it.
- (6) Set Monitor mode
 - ① When monitoring the output frequency, set indication code to d001, and press the **FUNC** key once.
 - ② Or when monitoring the operation direction, set indication code to d04, press the **FUNC** key once.
- (7) Press the **RUN** key to start operating.
(The "RUN" lamp turns on a light, and the indication changes in response to the monitor mode set.)
- (8) Press the **STOP** key to decelerate to a stop.
(When the frequency returns to 0, the RUN lamp light will switch off.)

4. Parameter Code List

4.1 About Digital Operator

4.1.1 Name and contents of each part of Standard-type digital operator

(1) Part name

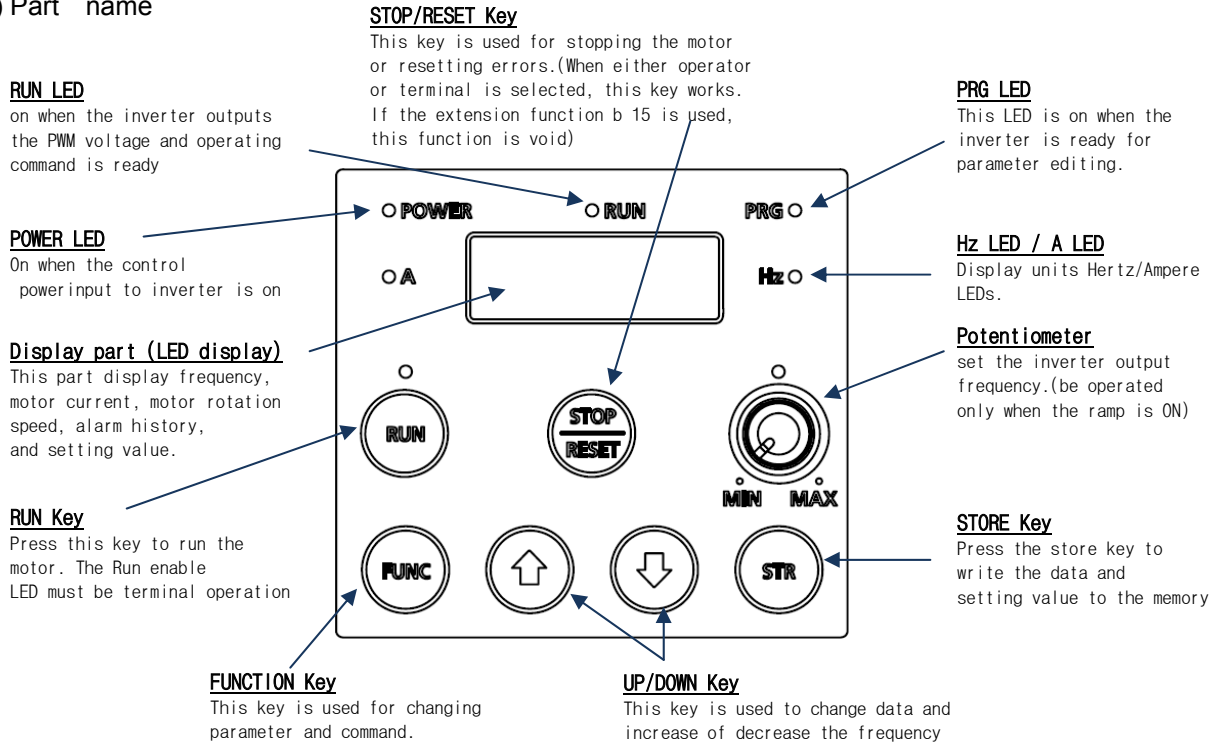
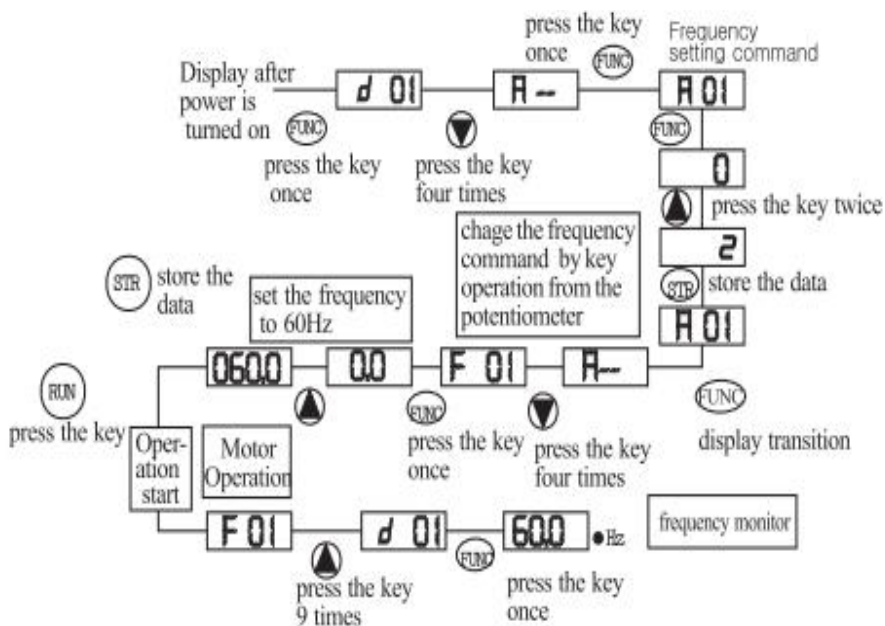

Fig.4-1 LED Type Digital Operator

(2) Operation procedure

- ① Example that the frequency is set from potentiometer to the standard operator and the equipment starts running)



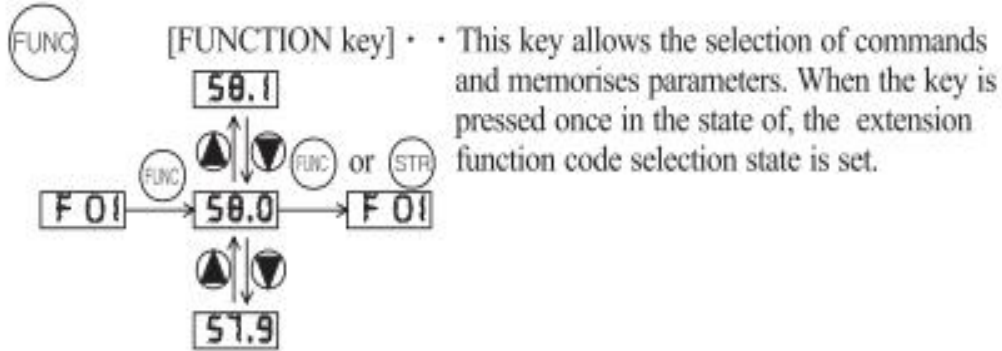

② Key Description

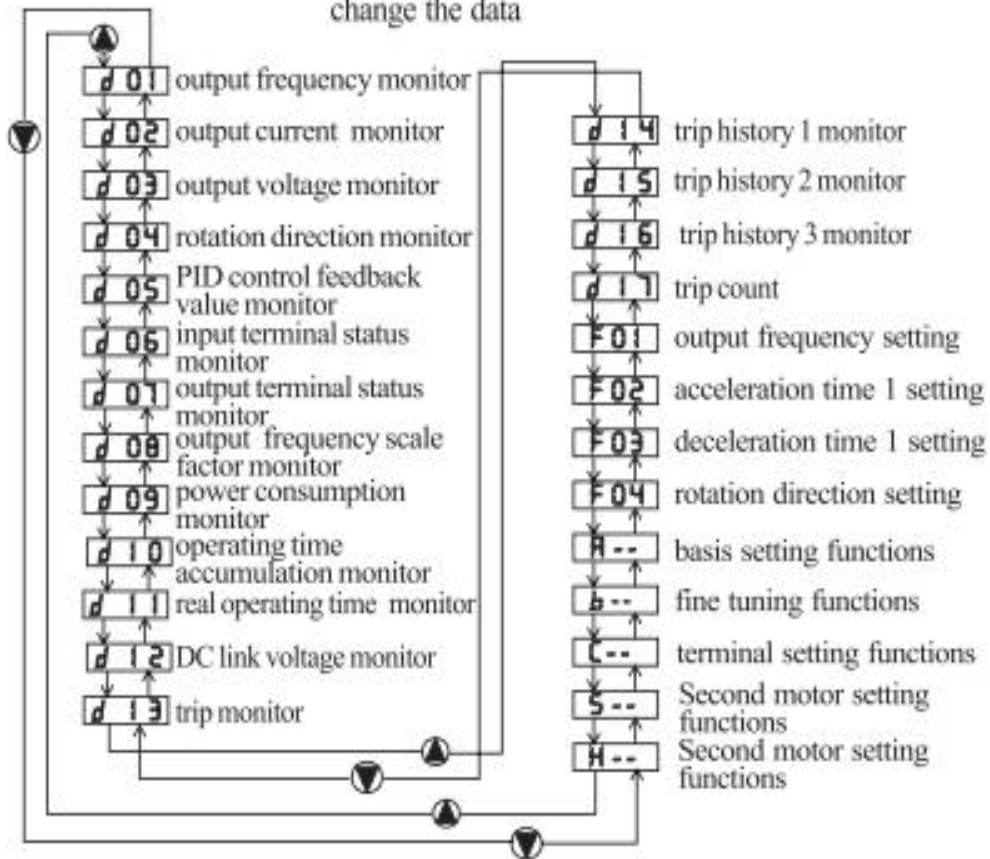

▲ ▼ [UP/DOWN key] · · The key are used to select the command and change the data



-  [RUN key] · · This key starts the run.
 The set value of **[F 04]** determines a forward run or a reverse run.
-  [STOP/RESET key] · · This key stops the run
 When a trip occurs, this key becomes the reset key.

Extended function mode navigation map

Using the ▲ / ▼ key to enter the expanded function mode, select expanded function command NO. in **A--** **b--** **C--** **S--** and **H--** mode.

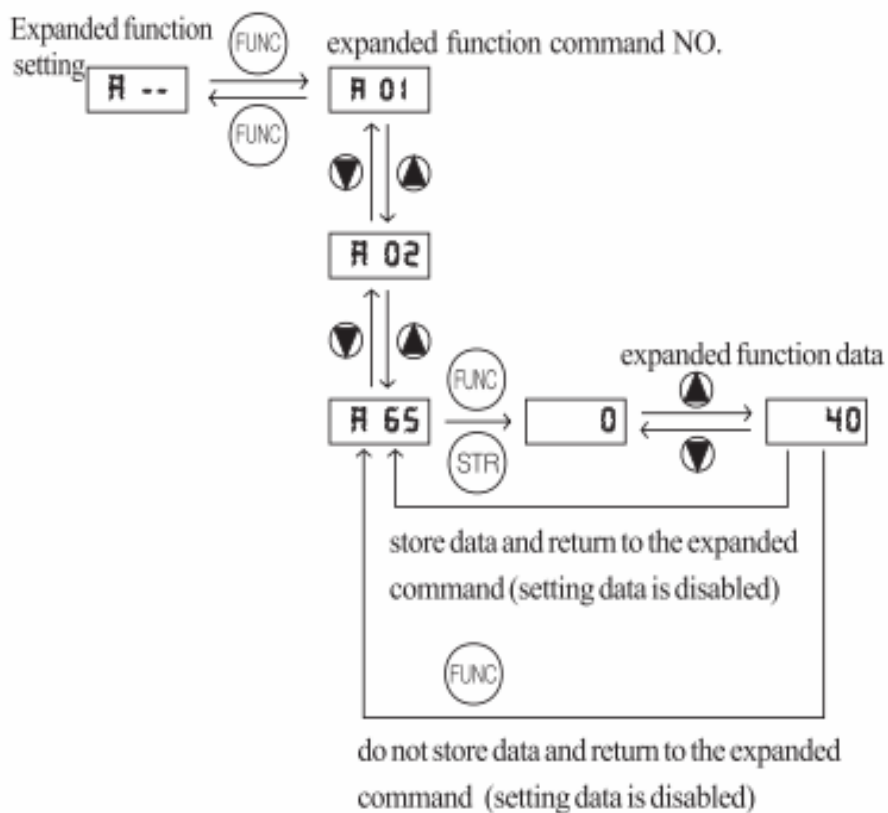



Display description:

When the inverter is turned on, the output frequency monitor display appears.

4.2 Function List

4.2.1 Monitor Mode (d-group)

Func-code	Name	Description
d01	Output frequency monitor	Real-time display of output frequency to motor, from 0.00 to 400.0 Hz, "Hz" LED ON
d02	Output current monitor	Real-time display of output current to motor, from 0.0 to 999.9A, "A" LED ON.
d03	Output voltage monitor	Real-time display of output voltage to motor
d04	Rotation direction monitor	Three different indications: "F"..... Forward Run "□"... Stop "r"..... Reverse Run
d05	PID feedback monitor	Displays the scaled PID process variable (feedback) value (A50 is scale factor)
d06	Intelligent input terminal status	Displays the state of the intelligent input terminals:  Terminal No. 6 5 4 3 2 1
d07	Intelligent output terminal status	Displays the state of the intelligent output terminals:  Terminal No. AL RN
d08	Scaled output frequency monitor	0 ~ 99.99/100.0 ~ 400.0 (= d01 x b14)
d09	Power consumption monitor	0 ~ 999.9 (kW)
d10	Operating time accumulation monitor(hour)	0 ~ 9999 (hr)
d11	Real operating time monitor (minute)	0 ~ 59 (min)
d12	DC link voltage	0 ~ 999 (V)

4.2.2 Trip & Warning monitor mode (d-group)

Func-code	Name	Description
d13	Trip event monitor	Displays the current trip event · Display method Alarm reason ↓ press the UP key Output frequency at alarm event ↓ press the UP/DOWN key Output current at alarm event ↓ press the UP/DOWN key DC link voltage at alarm event ↓ press the FUNC key "d13" display · No trip event
d14	Trip history 1 monitor	Displays the previous first trip event
d15	Trip history 2 monitor	Displays the previous second trip event
d16	Trip history 3 monitor	Displays the previous third trip event
d17	Trip count	Displays the trip accumulation count

4.2.3 Basic Function Mode

Func-code	Name	Description	Defaults	Run-time Edit
F01	Output frequency setting	Standard default target frequency that determines constant motor that determines constant motor speed. setting range is 0.00 to 400.0Hz (1) frequency setting from UP/DOWN key of digital operator. (2) Multi-step speed By combining frequency reference and intelligent input terminal ON/OFF, up to 16 step of speed can be set. (3) Remote operator (NOP), control terminal input (O-L, OI-L). Frequency reference by the local potentiometer can be monitored..	volume setting value	○
F02	Acceleration time1 setting	0.1 ~ 3000sec Minimum setting range 0.1 ~ 999.9 --- by 0.1sec 1000 ~ 3000 --- by 1sec	30.0sec	○
F03	Deceleration time 1 setting	0.1~3000sec Minimum setting range 0.1 ~ 999.9 --- by 0.1sec 1000 ~ 3000 --- by 1sec	30.0sec	○
F04	Rotation direction setting	Two options: select codes: 0... Forward run 1... Reverse run	0	X
A--	Extended function of A group setting	Basic setting functions setting range : A01 ~ A65.	-	-
b--	Extended function of b group setting	Fine tuning functions Setting range :b01 ~ b17.	-	-
C--	Extended function of C group setting	Terminal setting functions Setting range :C01 ~ C23	-	-
S--	Extended function of S group setting	Second motor setting functions Setting range :S01~S32.	-	-
H--	Extended function of H group setting	Sensorless vector setting functions Setting range :H01 ~ H15.	-	-

Note) If you set the carrier frequency less than 2kHz, acceleration / deceleration time delays approximately 500msec.

4.2.4 Expanded Function Mode of A Group

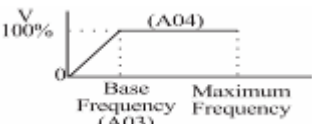
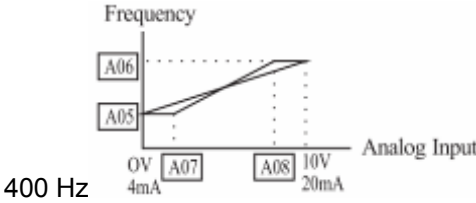
Func-code	Name	Run-time Edit	Description	Defaults
Basic parameter settings				
A01	Frequency command (Multi-speed command method)	X	Four options: select codes: 0.... Keypad potentiometer 1.... Control terminal input 2.... Standard operator 3.... Remote operator(communication)	0
A02	Run command	X	Set the method of run commanding: 0.... Standard operator 1.... Control terminal input 2.... Remote operator(communication)	0
A03	Base frequency setting	X	Settable from 0 to maximum frequency in units of 0.01Hz 	60.00Hz
A04	Maximum frequency setting	X	Settable from the base frequency [A03] up to 400Hz in units of 0.1 Hz.	60.00Hz
Analog Input Settings				
A05	External frequency setting start (O, OI)	X	Start frequency provided when analog input is 0V (4mA) can be set in units of 0.01Hz setting range is 0 to 	0.00Hz
A06	External frequency setting end (O, OI)	X	End frequency provided when analog input is 10V(20mA) can be set in units of 0.01Hz. setting range is 0 to 400Hz	0.00Hz
A07	External frequency start rate setting (O, OI)	X	The starting point(offset) for the active analog input range(0~10V, 4mA~20mA) setting range is 0 to 100% in units of 0.1%	0.0%
A08	External frequency end rate setting (O, OI)	X	The ending point(offset) for the active analog input range(0~10V, 4mA~20mA) setting range is 0 to 100% in units of 0.1%	100.0%

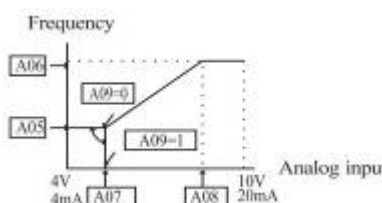
Func-code	Name	Run-time Edit	Description	Defaults
A09	External frequency start pattern setting	X	<p>Two options: select codes:</p>  <p>0--- start at start frequency 1--- start at 0Hz</p>	0
A10	External frequency sampling setting	X	Range n = 1 to 8, where n = number of samples for average	4
Multi-speed Frequency Setting				
A11 ~ A25	Multi-speed frequency setting	o	<ul style="list-style-type: none"> · Defines the first speed of a multi-speed profile, range is 0 to 400Hz in units of 0.01Hz. · Setting range is 1-speed(A11) to 15-speed(A25). · Speed0: volume setting value 	speed1:5Hz speed2:10Hz speed3:15Hz speed4:20Hz speed5:30Hz speed6:40Hz speed7:50Hz speed8:60Hz etc. 0Hz
A26	Jogging frequency setting	o	Defines limited speed for jog, range is 0.5 to 10.00Hz in units of 0.01Hz. The jogging frequency is provided safety during manual operation.	0.50Hz
A27	Jogging stop operation selection	X	Define how end of jog stops the motor: three options: 0.... Free-run stop 1.... Deceleration stop(depending on deceleration time) 2.... DC braking stop(necessarg to set DC braking)	0
V/F Characteristics				
A28	Torque boost mode selection	X	Two options: 0.... Manual torque boost 1.... Automatic torque boost	0

Func-code	Name	Run-time Edit	Description	Defaults
A29	Manual torque boost setting	○	<p>Can boost starting torque between 0 and 100% above normal V/F curve, from 0 to 1/2 base frequency. Be aware that excessive torque boost can cause motor damage and inverter trip.</p>	1.0%
A30	Manual torque boost frequency setting	○	<p>Sets the frequency of the V/F breakpoint A in graph for torque boost.</p>	10.0%
A31	V/F characteristic curve selection	×	<p>Two available V/F curves: three select codes: 0... Constant torque 1... Reduced torque(reduction of the 1.7th power) 2... Sensorless vector control</p>	0
A32	V/F gain setting	○	<p>Sets output voltage gain of the inverter from 20 to 110%. 100% 이상 설정은 출력 전압이 입력 전압보다 작은 경우에만 해당됩니다.</p>	100.0%
DC Braking Settings				
A33	DC braking function selection	×	<p>Sets two options for DC braking 0... Disable 1... Enable</p>	0
A34	DC braking frequency setting	×	<p>The frequency at which DC braking occurs, range is 0.0 to 10.0 Hz in units of 0.01Hz</p>	0.50Hz
A35	DC braking output delay time setting	×	<p>The delay from the end of Run command to start of DC braking (motor free runs until DC braking begins). Setting range is 0.0 to 5.0sec in units of 0.1sec.</p>	0.0sec
A36	DC braking force setting	×	<p>Applied level of DC braking force settable from 0 to 50% in units of 0.1%</p>	10.0%
A37	DC braking time setting	×	<p>Sets the duration for DC braking, range is 0.0 to 10.0 seconds in units of 0.1sec.</p>	0.0sec

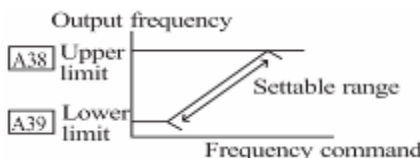
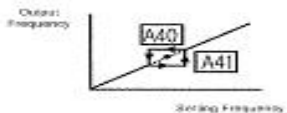
Func-code	Name	Run-time Edit	Description	Defaults
Frequency-related Functions				
A38	Frequency upper limit setting	X	<p>Sets a limit on output frequency less than the maximum frequency(A04). Range is 0.00 to 400.0Hz in units of 0.01Hz.</p> 	0.00Hz
A39	Frequency lower limit setting	X	<p>Sets a limit on output frequency greater than zero. Range is 0.00 to 400.0Hz in units of 0.01Hz</p>	0.00Hz
A40 A42 A44	Jump(center) frequency setting	X	<p>Up to 3 output frequencies can be defined for the output to jump past to avoid motor resonances(center frequency) range is 0.00 to 400.0Hz in units of 0.01Hz..</p>	0.00Hz
A41 A43 A45	Jump(hysteresis) frequency width setting	X	<p>Defines the distance from the center frequency at which the jump around occurs. Range is 0.00 to 10.00Hz in units of 0.01Hz</p> 	0.00Hz
PID Control(Note1)				
A46	PID Function selection	X	<p>Enables PID function, two option codes: 0.... PID control disable 1.... PID control enable</p>	0
A47	PID P(proportional) gain setting	○	<p>Proportional gain has a range of 0.1 to 100 in the units of 0.1</p>	10.0%
A48	PID I (integral) gain setting	○	<p>Integral time constant has a range of 0.0 to 100.0 seconds in units of 0.1</p>	10.0초
A49	PID D(derivative) gain setting	○	<p>Derivative gain has a range of 0.0 to 100.0 seconds in units of 0.1</p>	0.0초
A50	PID scale factor setting	X	<p>PID scale factor (multiplier), range of 0.1 to 1000 in units of 0.1.</p>	100.0
A51	Feed-back method setting	X	<p>Selects source of PID, option codes: 0.... "OI" terminal(current in put) 1.... "O" terminal(voltage in put)</p>	0

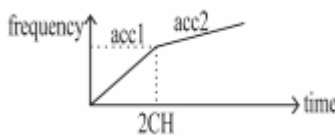
Func - code	Name	Run-time Edit	Description	Defaults
Automatic Voltage Regulation (AVR) Function				
A52	AVR function selection	X	Automatic (output) voltage regulation, selects from three type of AVR functions three option codes: 0... Constant ON 1... Constant OFF 2... OFF during deceleration	0
A53	Motor input voltage setting	X	200V class inverter settings: 200/220/230/240 400V class inverter settings: 380/400/415/440/460/480 The AVR feature keeps the inverter output waveform at a relatively constant amplitude during power input fluctuations	220V/ 380V
Second Acceleration and Deceleration Functions				
A54	Second acceleration time setting	○	Duration of 2nd segment of acceleration, range is 0.1 to 3000 sec. Second acceleration can be set by the [2CH] terminal input or frequency transition setting	10.0sec
A55	Second deceleration time setting	○	Duration of 2nd segment of deceleration, motor, range is 0.1 to 3000 sec. Second acceleration can be set by the [2CH] terminal input or frequency transition setting	10.0초
A56	Two stage acce1/dece1 switching method selection	X	Two options for switching from 1st to 2nd accel/decel: 0.... 2CH input from terminal 1.... transition frequency 	0
A57	Acc1 to Acc2 frequency transition point	X	Output frequency at which Accel 1 switches to Acce1 2, range is 0.00 to 400.0Hz in units of 0.01Hz.	0.00Hz
A58	Decl to Dec2 frequency transition point	X	Output frequency at which Decel 1 switches to Dece1 2, range is 0.00 to 400.0Hz in units of 0.01Hz.	0.00Hz

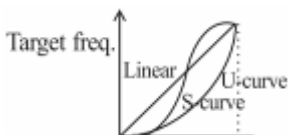
Func-code	Name	Run-time Edit	Description	Defaults
A59	Acceleration curve selection	X	Set the characteristic curve of Acc1 and Acc2, two options: <ul style="list-style-type: none"> 0 --- Linear 1 --- S-curve (max. acceleration time : 39.0sec) 2 --- U-curve (max. acceleration time : 29.0sec) 	0
A60	Deceleration curve setting	X	Set the characteristic curve of dec1 and dec2, two options: <ul style="list-style-type: none"> 0 --- Linear 1 --- S-curve (max. deceleration time : 39.0sec) 2 --- U-curve (max. deceleration time : 29.0sec) 	0
A61	Input voltage offset setting	○	Set the voltage offset for external analog signal input signal adjustment	0.0
A62	Input voltage Gain setting	○	Set the voltage gain for external analog signal input signal adjustment	100.0
A63	Input current offset setting	○	Set the current offset for external analog signal input signal adjustment	0.0
A64	Input current Gain setting	○	Set the current gain for external analog signal input signal adjustment	100.0
A65	FAN operation mode	X	Set the FAN operation mode <ul style="list-style-type: none"> 0: always ON 1: ON in the run time 	0

Note 1) PID feedback control

The PID(Proportional, Integral, Differential) control functions can apply to controlling of fan, the air (water) amount of pump, etc., as well as controlling of pressure within a fixed value.

[Input method of target value signal and feedback signal]

Set the reference signal according to the frequency setting method or the internal level.

Set the feedback signal according to the analog voltage input (0 to 10V) or analog current input (4 to 20mA).

If both input signal (target value and feedback value) set the same terminal, PID control is not available.

To use analog current [OI-L] for the target value, set the [AT] terminal to ON.

[PID gain adjustment]

If the response is not stabilized in a PID control operation, adjust the gains as follows according to the symptom of the inverter.

- The change of controlled variable is slow even when the target value is changed. → Increase P gain [A47]
- The change of controlled variable is fast, but not stable. → Decrease P gain[A47]
- It is difficult to make the target value match with the controlled variable. → Decrease I gain [A48]
- Both the target value and the controlled variable are not stable. → Increase I gain [A48]
- The response is slow even when the P gain is increased. → Increase D gain[A49]
- The response is not stabilized due to oscillation even when the P gain is increased. → Decrease D gain[A49]

The figure below is a more detailed diagram of the PID control.

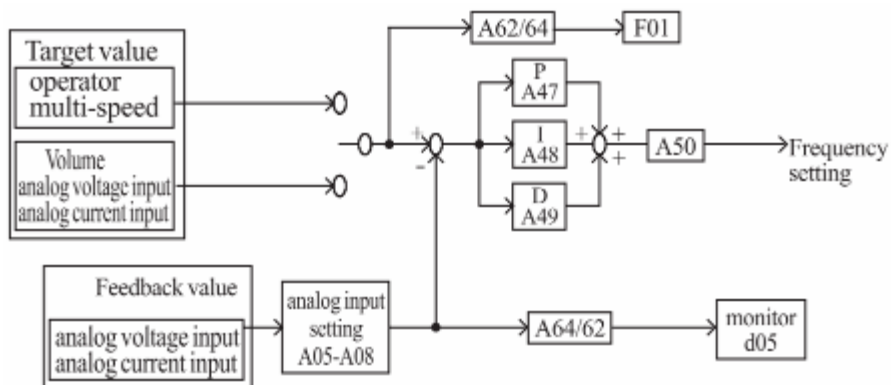

4.2.5 Expanded function mode of B group

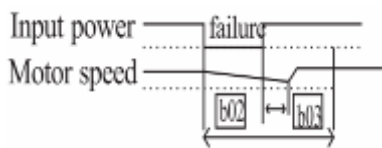
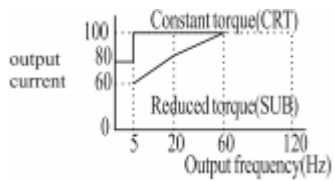
Func-code	Name	Run-time Edit	Description	Defaults
Restart Mode				
b01	Selection of restart mode	X	<p>Select inverter restart method, four option codes:</p> <p>0.... Alarm output after trip, no automatic restart</p> <p>1.... Restart at 0Hz</p> <p>2.... Resume operation after frequency matching</p> <p>3.... Resume previous freq. after freq. matching, then decelerate to stop and display trip info.</p> <ul style="list-style-type: none"> · Restart trip is overcurrent, overvoltage and under voltage. · Overcurrent and over voltage trip restart up to 3 times, under voltage trip restart up to 10time. 	0
b02	Allowable instantaneous power failure time setting	X	<p>The amount of time a power input under voltage can occur without tripping the power failure alarm. Range is 0.3 to 1.0 sec. If under-voltage exists longer than this time, the inverter trips, even if the restart mode is selected.</p>	1.0sec
b03	Reclosing stand by after Instantaneous power failure recovered	X	<p>Time delay after under-voltage condition goes away, before the inverter runs motor again. Range is 0.3 to 3.0 seconds.</p> 	1.0sec
Electronic Thermal Overload Alarm Setting				
b04	Electronic thermal level setting	X	<p>Set a level between 20% and 120% for the rated inverter current.</p> <p>setting range- $0.2 \times$ (inverter rated current) $\sim 1.2 \times$ (inverter rated current).</p>	100.0%
b05	Electronic thermal characteristic, selection	X	<p>Select from two curves, option codes:</p> <p>0....(SUB) reduced torque characteristic</p> <p>1....(CRT) constant torque characteristic</p> 	1

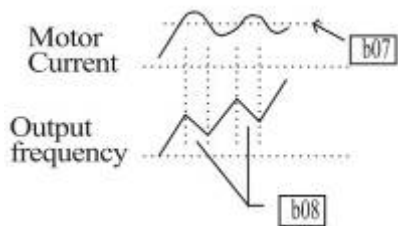
Func-code	Name	Run-time Edit	Description	Defaults
Overload Restriction				
b06	Overload overvoltage Restriction mode selection	X	Select overload or overvoltage restriction modes 0.... Overload, overvoltage restriction mode OFF 1.... Only overload restriction mode ON 2.... Only overvoltage restriction mode ON 3.... Overload overvoltage restriction mode ON	1
b07	Overload restriction level setting	X	Sets the level for overload restriction, between 20% and 200% of the rated current of the inverter, setting range 0.2x(inverter rated current) ~ 2.0x(inverter rated current)	150%
b08	Overload restriction constant setting	X	Set the deceleration rate when inverter detects overload, range is 0.1 to 10.0 and resolution is 0.1 	0.1sec
Software Lock Mode				
b09	Software lock mode selection	X	Prevents parameter changes, in four options, option codes: 0.... All parameters except b09 are locked when SFT from terminal is on 1.... All parameters except b09 and output frequency F01 are locked when SFT from terminal is ON 2.... All parameters except b09 are locked 3.... All parameters except b09 and output frequency F01 setting are locked	0

Func-code	Name	Run-time Edit	Description	Defaults
Other Function				
b10	Start frequency Adjustment	X	Sets the starting frequency for the inverter output, range is 0.50 to 10.00Hz in units of 0.01Hz	0.50Hz
b11	Carrier frequency setting	O	Sets the PWM carrier frequency, range is 0.5 to 15.0kHz in units of 0.1kHz. Default value of 22kW inverter is 3.0kHz. Maximum value of 18.5 and 22kW inverter is 10.0kHz.	5.0kHz
b12	Initialization mode (parameters or trip history)	X	Select the type of initialization to occur, two option codes: 0.... Trip history clear 1.... Parameter initialization	0
b13	Country code for initialization	X	Select default parameter values for country on initialization, three options, option codes: 0.... Korea version 1.... Europe version 0- 2.... US version	0
b14	Frequency scalar conversion facto	o	Specify a constant to scale the displayed frequency for [d08] monitor, range is 0.01 to 99.9 in units of 0.01	1.00
b15	STOP key validity during terminal operation	X	Select whether the STOP key on the keypad is enabled, two option codes: 0.... stop enabled 0- 1.... stop disabled	0
b16	Resume on FRS cancellation mode	X	Select how the inverter resumes operation when the free-run stop (FRS) is cancelled, two options: 0... Restart from 0Hz 1....Restart from frequency detected from real speed of motor 2.....Free run stop	0
b17	Communication number	X	Sets the communication number for communication, range is 1 to 32.	1
b18	Ground fault setting	X	Select the function and level of ground fault.. 0 : Do not detect ground fault. 0.1~100.0% : Detect ground fault as the % level of rated current.	0.0

4.2.6 Expanded Function Mode of C Group

Func-code	Name	Run-time Edit	Description	Defaults
Input Terminal Function				
C01	Intelligent Input terminal 1 setting	X	Select function for terminal 1 <code> 0: Forward run command(FW) 1: Reverse run command(RV) 2: 1st multi-speed command(CF1) 3: 2nd multi-speed command(CF2) 4: 3rd multi-speed command(CF3) 5: 4th multi-speed command(CF4) 6: Jogging operation command(JG) 7: 2nd function setting command(SET) 8: 2-stage acceleration/deceleration command(2CH) 9: free-run stop command(FRS) 10:external trip(EXT) 11:unattended start protection(USP) 12:software lock function(SFT) 13.analog input current/voltage selection signal(AT) 14:reset(RS)	0
C02	Intelligent Input terminal 2 setting	X	Select function for terminal 2 <code>-see C01 parameter	1
C03	Intelligent Input terminal 3 setting	X	Select function for terminal 3 <code>-see C01 parameter	2
C04	Intelligent Input terminal 4 setting	X	Select function for terminal 4 <code>-see C01 parameter	3
C05	Intelligent Input terminal 5 setting	X	Select function for terminal 5 <code>-see C01 parameter	13
C06	Intelligent Input terminal 6 setting	X	Select function for terminal 6 <code>-see C01 parameter	14

Func-code	Name	Run-time Edit	Description	Defaults
Input Terminal Status				
C07	Input Terminal 1 a/b contact setting (NO/NC)	X	Select logic convention, two option codes: 0.... normally open [NO] 1.... normally closed [NC]	0
C08	Input Terminal 2 a/b contact setting (NO/NC)	X	Select logic convention, two option codes: 0.... normally open [NO] 1.... normally closed [NC].	0
C09	Input Terminal 3 a/b contact setting (NO/NC)	X	Select logic convention, two option codes: 0.... normally open [NO] 1.... normally closed [NC]	0
C10	Input Terminal 4 a/b contact setting (NO/NC)	X	Select logic convention, two option codes: 0.... normally open [NO] 1.... Normally closed [NC].	0
C11	Input Terminal 5 a/b contact setting (NO/NC)	X	Select logic convention, two option codes: 0.... normally open [NO] 1.... Normally closed [NC].	0
C12	Input Terminal 6 a/b contact setting (NO/NC)	X	Select logic convention, two option codes: 0.... normally open [NO] 1.... Normally closed [NC].	0
Output Terminal Function				
C13	Intelligent output terminal RN setting	X	Select function for terminal RN <code> 0... RUN(Run signal) 1.... FA1(Frequency arrival signal: command arrival) 2.... FA2(Frequency arrival signal: setting frequency or more) 3.... OL(Overload advance notice signal) 4.... OD(Output deviation for PID control) 5.... AL(Alarm signal)	1
C14	Output Terminal RN a/b contact setting	X	Select logic convention, two option codes: 0.... normally open [NO] 1.... normally closed [NC]	0
C15	Monitor signal selection	X	Select function for terminal FM, 3 options 0.... output frequency monitor 1.... output current monitor 0- 2.... output voltage monitor	0

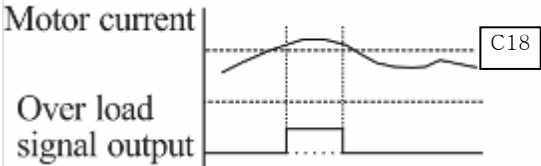
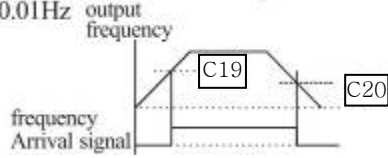
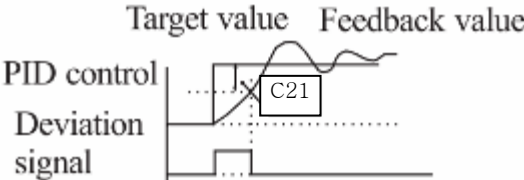
Func - code	Name	Run-time Edit	Description	Defaults
Output Terminal state setting				
C16	Analog meter gain adjustment	○	Range is 0 to 250, resolution is 1	100.0%
C17	Analog meter offset adjustment	○	Range is -3.0 to 10.0% resolution is 0.1	0.0%
Output Terminal related function				
C18	Overload advance notice signal level setting	X	<p>Sets the overload signal level between 50% and 200% resolution is 0.1%.0.5x(Inverter rated current) ~ 2.0x (Inverter rated current)</p> 	100.0%
C19	Acceleration arrival signal frequency setting	X	<p>Sets the frequency arrival setting thres-hold for the output frequency during acceleration. Setting range is 0.0 to A04, resolution is 0.01Hz</p> 	0.00Hz
C20	Deceleration arrival signal frequency setting	X	<p>Sets the frequency arrival setting thres-hold for the output frequency during deceleration, setting range is 0.00 to 400.0Hz resolution is 0.01Hz</p>	0.00Hz
C21	PID deviation level setting	X	<p>Sets the allowable PID loop error magnitude. Setting range is 0.0 to 100%, resolution is 0.01%</p> 	1.0%

4.2.7 Expanded function mode of S group

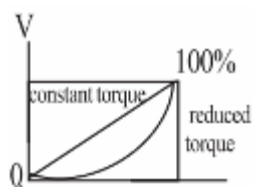
Func-code	Name	Run-time Edit	Description	Defaults
S01	2nd control, Multi-speed frequency setting	○	Range is 0.0 to 400Hz in units of 0.01Hz (It is enabled by the frequency demanding in the standard operator)	0속: 60.0Hz
S02	2nd control ,Acceleration time	○	Range is 0.1~3,000sec <div style="border: 1px solid black; padding: 2px; display: inline-block;"> Minimum setting Unit 0.1~999.9 ---- by 0.1sec 1000~3000 --- by 1sec </div>	10.0초
S03	2nd control, Deceleration time	○	Range is. 0.1~3000sec <div style="border: 1px solid black; padding: 2px; display: inline-block;"> Minimum setting Unit 0.1~999.9 ---- by 0.1sec 1000~3000 --- by 1sec </div>	10.0초
S04	2nd control,Base frequency	X	Range is 0 to S05 (second control maximum frequency) in units of 0.1Hz	60Hz
S05	2nd control,maximum frequency	X	Range is S04(second control base frequency) to 400.00Hz in units of 0.1Hz.	60Hz
S06	2nd control,torque boost mode selection	X	Two selections, option codes : 0 --- manual torque boost 1 --- automatic torque boost	0
S07	2nd control,manual torque boost setting	○	Set the manual torque boost voltage. Adjust the motor torque by boosting the output voltage above the normal V/F ratio. Be aware that excessive torque boost can cause motor damage and inverter trip.	5.0%
S08	2nd control,manual torque boost frequency adjustment	○	The boost is applied from 0 to 50% the base frequency..	10.0%
S09	2nd control,V/F Characteristic curve selection	X	Set the V/F characteristics 0 --- constant torque 1 --- reduced torque (the 1.7th power) 2 --- sensorless vector control 	0

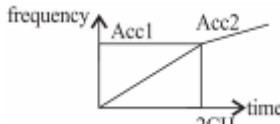
Func-code	Name	Run-time Edit	Description	Defaults
S10	2nd control, acceleration time 2 setting	○	Range is 0.1 to 999.9sec in units of 0.1sec, 1000~3000sec in units of 1 sec. Second acceleration can be set by the [2CH] terminal input or frequency transition setting	10.0초
S11	2nd control, deceleration time 2 setting	○	Range is 0.1 to 999.9sec in units of 0.1sec, 1000~3000sec in units of 1 sec. Second acceleration can be set by the [2CH] terminal input or frequency transition setting	10.0초
S12	2nd control, acceleration pattern setting	○	Set the characteristic curve of Acc 1 and Acc2, three options. 0:linear, 1:S-curve, 2:U-curve	0
S13	2nd control, deceleration pattern setting	X	Set the characteristic curve of Dec 1 and Dec2, three options. 0:linear, 1:S-curve, 2:U-curve	0
S14	2nd control, 2-stage Accel./decel. transition method setting	X	0 --terminal(2CH), 1 -- transition frequency 	0
15	2nd control, acceleration transition frequency setting	X	Output frequency at which Acc1 switches to Acc2, range is 0.0 to 400.0Hz in units of 0.01Hz	0.00Hz
16	2nd control, deceleration transition frequency setting	○	Output frequency at which Dcc1 switches to Dcc2, range is 0.0 to 400.0Hz in units of 0.01Hz	0.00Hz
17	2nd control, electronic thermal level setting	○	Set a level between 20% to 120% for the rated inverter current setting range : 0.2x(inverter ratedcurrent) ~1.2x(inverter ratedcurrent)	100.0%
18	2nd control, Electronic thermal characteristic setting	X	Considering on the overload, the electronic thermal protects against the motor from overheating 0 ---- SUB, 1 ---- CRT	1
19	2nd control motor constant setting	X	0 : standard motor constants 1 : auto tune data	0

Func-code	Name	Run-time Edit	Description	Defaults
S20	2nd control, motor capacity selection	X	0 : 220V / 2.2kW 1 : 220V / 3.7kW 2 : 220V / 5.5kW 3 : 220V / 7.5kW 4 : 220V / 11kW 5 : 220V / 15kW 6 : 220V / 18.5kW 7 : 220V / 22kW 8 : 220V / 30kW 9 : 380V / 2.2kW 10 : 380V / 3.7kW 11 : 380V / 5.5kW 12 : 380V / 7.5kW 13 : 380V / 11kW 14 : 380V / 15kW 15 : 380V / 18.5kW 16 : 380V / 22kW 17 : 380V / 30kW	-
S21	2nd control, motor poles selection	X	2/4/6/8	4
S22	2nd control, motor rated current selection	X	The setting depend on the motor capacity	-
S23	2nd control, motor no-load current I0	X	setting range : 0.1 – 100.0A	-
S24	2nd control, motor rated slip	X	setting range : 0.01 – 10.0%	-
S25	2nd control, motor constant R1	X	Setting range 0.001 - 30.00Ω	-
S26	2nd motor control leakage factor	X	Setting range 0.01 – 100.0mH	-
S27	2nd motor constant R1 auto-tuning data	X	Setting range 0.001 - 30.00Ω	-
S28	2nd motor constant leakage factor auto-tuning data	X	Setting range 0.01 – 100.0mH	-

4.2.8 Expanded Function mode of H Group

Func-code	Name	Run-time Edit	Description	Defaults																		
H01	Auto-tuning mode selection	X	Two States for auto-tuning function, option codes: 0.... Auto-tuning OFF 1.... Auto-tuning ON	0																		
H02	Motor data selection	X	Two selections, option codes: 0...Use standard motor data 1...Use auto-tuning data	0																		
H03	Motor capacity	X	<table style="width: 100%; border: none;"> <tr> <td style="width: 50%;">0 : 220V / 2.2kW</td> <td style="width: 50%;">9 : 380V / 2.2kW</td> </tr> <tr> <td>1 : 220V / 3.7kW</td> <td>10 : 380V / 3.7kW</td> </tr> <tr> <td>2 : 220V / 5.5kW</td> <td>11 : 380V / 5.5kW</td> </tr> <tr> <td>3 : 220V / 7.5kW</td> <td>12 : 380V / 7.5kW</td> </tr> <tr> <td>4 : 220V / 11kW</td> <td>13 : 380V / 11kW</td> </tr> <tr> <td>5 : 220V / 15kW</td> <td>14 : 380V / 15kW</td> </tr> <tr> <td>6 : 220V / 18.5kW</td> <td>15 : 380V / 18.5kW</td> </tr> <tr> <td>7 : 220V / 22kW</td> <td>16 : 380V / 22kW</td> </tr> <tr> <td>8 : 220V / 30kW</td> <td>17 : 380V / 30kW</td> </tr> </table>	0 : 220V / 2.2kW	9 : 380V / 2.2kW	1 : 220V / 3.7kW	10 : 380V / 3.7kW	2 : 220V / 5.5kW	11 : 380V / 5.5kW	3 : 220V / 7.5kW	12 : 380V / 7.5kW	4 : 220V / 11kW	13 : 380V / 11kW	5 : 220V / 15kW	14 : 380V / 15kW	6 : 220V / 18.5kW	15 : 380V / 18.5kW	7 : 220V / 22kW	16 : 380V / 22kW	8 : 220V / 30kW	17 : 380V / 30kW	
0 : 220V / 2.2kW	9 : 380V / 2.2kW																					
1 : 220V / 3.7kW	10 : 380V / 3.7kW																					
2 : 220V / 5.5kW	11 : 380V / 5.5kW																					
3 : 220V / 7.5kW	12 : 380V / 7.5kW																					
4 : 220V / 11kW	13 : 380V / 11kW																					
5 : 220V / 15kW	14 : 380V / 15kW																					
6 : 220V / 18.5kW	15 : 380V / 18.5kW																					
7 : 220V / 22kW	16 : 380V / 22kW																					
8 : 220V / 30kW	17 : 380V / 30kW																					
H04	Motor poles setting	X	2/4/6/8	4																		
H05	Motor rated current	X	Range is 0.1 – 200.0A	-																		
H06	Motor no-load current I ₀	X	Range is 0.1 – 100.0A	-																		
H07	Motor rated slip	X	Range is 0.01 – 10.0%	-																		
H08	Motor Resistance R1	X	Range is 0.001 - 30.00Ω	-																		
H09	Transient Inductance	X	Range is 0.01 – 100.00mH	-																		
H10	Motor Resistance R1	X	Range is 0.001 - 30.00Ω	-																		
H11	Transient Inductance	X	Range is 0.01 – 100.00mH	-																		

5. Using intelligent terminals

5.1 Intelligent terminal lists

Terminal symbol	Terminal name	Description	
FW (0)	Forward RUN/STOP terminal	SWF switch ON(closed) :Forward run OFF(open) : stop	
	RV (1)	Reverse RUN/STOP terminal	SWR switch ON(closed) :Reverse run OFF(open) :stop
Intelligent Input Terminal (1-6)	CF (2)	Multi-speed frequency commanding terminal	1
	CF (3)		2
	CF (4)		3
	CF (5)		4
	JG (6)	Jogging	Jogging operation
SET (7)	Second control function	You may change the setting value when only one inverter connects two motors(output frequency setting, acceleration/ deceleration time setting, manual torque boost setting, elect- onic thermal setting, motor capacity setting, control method)	
2CH (8)	2-stage acceleration/deceleration	The acceleration or deceleration time is possible to change considering the system.	
FRS (9)	Free-run stop	The inverter stops the output and the motor enters the free- run state.(coasting)	
EXT (10)	External trip	It is possible to enter the external trip state	
USP (11)	Unattended start prevention	Restart prevention when the power is turned on in the RUN state.	
SFT (12)	Terminal soft-ware lock	The data of all the parameters and functions except the output frequency is locked.	
AT (13)	Current input selection	The [AT] terminal selects the inverter uses the voltage [O] or current [OI] input terminals for external frequency control.	
RS (14)	Reset	If the inverter is in Trip Mode, the reset cancels the Trip Mode.	
CM1	Signal source for input	Common terminal for intelligent input terminals.	
P24	External power supply terminal for input	External power connection terminal for intelligent input terminals.	

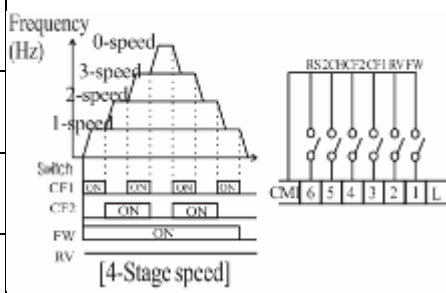
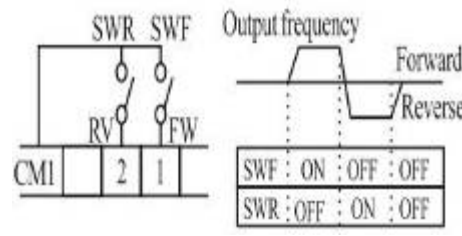

Default terminal setting
 Terminal1 : FW
 Terminal 2 : RV
 Terminal 3 : CF1
 Terminal 4 : CF2
 Terminal 5 : AT
 Terminal 6 : RS

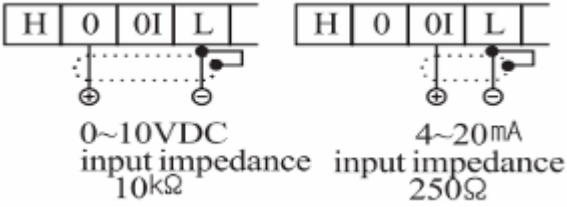
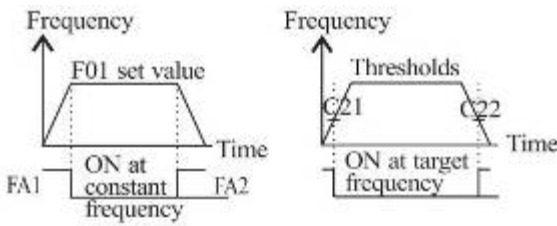
Terminal symbol		Terminal name	Description	
Frequency commanding	H	Frequency command power terminal	When assign 13[AT signal] to code C01~C06 AT signal ON : It is possible to command frequency using voltage signal terminal O-L(0~10V) AT signal OFF : It is possible to command frequency using current signal terminal OI-L(4~20mA) When nog assign 13[AT signal] to code C01~C06 It is possible to commend frequency use the algebraic sum of both the voltage and current input 	
	O	Frequency commanding terminal(voltage commanding)		
	OI	Frequency commanding terminal(current command)		
	L	Frequency command common terminal		
Monitor termina	FM	Frequency monitor	Analog output frequency monitor/ analog output current monitor/ analog output voltage monitor	
Intelligent output terminal (RN)	FA1 (1) FA2 (2)	Frequency arrival signal	Frequency arrival [FA1][FA2] signals is indicated when the output frequency accelerates and decelerates to arrive at a constant frequency. 	Output terminal specification 250VAC, 2A(Resistive load) 30VDC, 2A(Resistive load)
	RUN (0)	Run signal	When the [RUN] signal is selected, the inverter outputs a signal on that terminal when it is in the RUN mode.	
	OL (3)	Overload advance notice signal	When the output current exceeds a preset value, the [OL] terminal signal turns on.	
	OD (4)	PID control error deviation signal	When the PID loop error magnitude the preset value, the [OD] terminal signal turns on.	
	AL (5)	Alarm signal	The inverter alarm signal is active when a fault has occurred.	
AL0	Alarm terminals	At normal status, power off(initial setting value) : A10 - AL1(closed) At abnormal status : AL0 - AL2(closed)		
AL1		Contact rating : 250V AC 2.5A(resistor 1oad) 0.2A(inductor load) 30V DC 3.0A(resistor 1oad) 0.7A(inductor load) (minimum 100V AC 10mA, 5V DC 100mA)		
AL2				

5.2 Monitor terminal function

Monitor terminal function [FM] (analog)

- The inverter provides an analog output terminal primary for frequency monitoring on terminal [FM] (output frequency, Output current, and output voltage monitor signal).
- Parameter C17 selects the output signal data.
When using the analog motor for monitoring, use scale reactor C18 and C19 to adjust the [FM] output so that the maximum frequency in the inverter corresponds to full-scale reading on the motor.

(1) output frequency monitor signal

The [FM] output duty cycle varies with the inverter output frequency.

The signal on [FM] reaches full scale when the inverter outputs the maximum frequency.

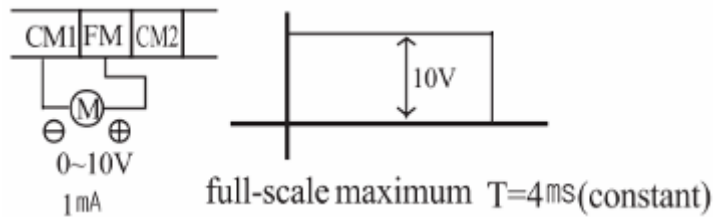

Note) This is dedicated indicator, so that it cannot be used as a line speed signal.

The indicator accuracy after adjustment is about $\pm 5\%$

(Depending on the meter, the accuracy may exceed this value)

(2) output current monitor signal

The [FM] output duty cycle varies with the inverter output current to the motor.

The signal on [FM] reaches full scale when the inverter output current reaches 200% of the rated inverter current.

The accuracy of the current reaches approximately $\pm 10\%$

inverter output current (measured) : I_m
 monitor display current : I_m'
 inverter rated current : I_r

$$\frac{I_m' - I_m}{I_r} \times 100 \leq \pm 10\%$$

(3) output voltage monitor signal

The [FM] output duty cycle varies with inverter output voltage.

The signal on [FM] reaches full scale when the inverter output voltage reaches 100% of the rated inverter voltage.

5.3 Intelligent Input Terminal Function

Forward Run/Stop [FW] and Reverse Run/Stop Command [RV]

- When you input the Run command via the terminal [FW], the inverter executes the Forward Run command (high) or Stop command(low)
- When you input the Run command via the terminal [RV], the inverter executes the Reverse Run command (high) or Stop command(low).

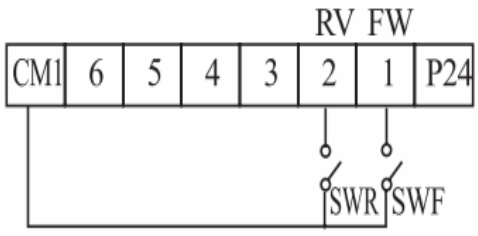
Option Code	Terminal Symbol	Function Name	State	Description
0	FW	Forward Run/Stop	ON	Inverter is in Run Mode, motor runs forward
			OFF	Inverter is in Run Mode, motor stop
1	RV	Reverse Run/Stop	ON	Inverter is in Run Mode, motor runs reverse
			OFF	Inverter is in Run Mode, motor runs stop
Valid for inputs: Required setting		C01,C02,C03,C04, C05,C06 A02=01		Example: 
Notes: <ul style="list-style-type: none"> • When the Forward Run and Reverse Run commands are active at the same time, the inverter enters the Stop Mode. • When a terminal associated with either [FW] or [RV] function is configured for normally closed, the motor starts rotation when that terminal is disconnected or otherwise has no input voltage. Set the parameter A02 to 1 				



DANGER : If the power is turned on and the Run command is already active, the motor starts rotation and is dangerous! Before turning power on, confirm that Run command is not active.

Multi-Speed Select [CF1][CF2][CF3][CF4]

- The inverter provides storage parameters for up to 16 different target frequencies (speeds) that the motor output uses for steady-state run condition. These speeds are accessible through programming four of the intelligent terminals as binary-encoded inputs CF1 to CF4 per the table . These can be any of the six inputs, and in any order. You can use fewer inputs if you need eight or less speeds.

Note : When choosing a subset of speeds to use, always start at the top of the table, and with the least-significant bit: CF1, CF2, etc.

Multi-speed	Control circuit terminal			
	SW5	SW4	SW3	SW2
Speed 0	OFF	OFF	OFF	OFF
Speed 1	OFF	OFF	OFF	ON
Speed 2	OFF	OFF	ON	OFF
Speed 3	OFF	OFF	ON	ON
Speed 4	OFF	ON	OFF	OFF
Speed 5	OFF	ON	OFF	ON
Speed 6	OFF	ON	ON	OFF
Speed 7	OFF	ON	ON	ON
Speed 8	ON	OFF	OFF	OFF
Speed 9	ON	OFF	OFF	ON
Speed 10	ON	OFF	ON	OFF
Speed 11	ON	OFF	ON	ON
Speed 12	ON	ON	OFF	OFF
Speed 13	ON	ON	OFF	ON
Speed 14	ON	ON	ON	OFF
Speed 15	ON	ON	ON	ON

NOTE : Speed 0 is set by the **F01** parameter value.

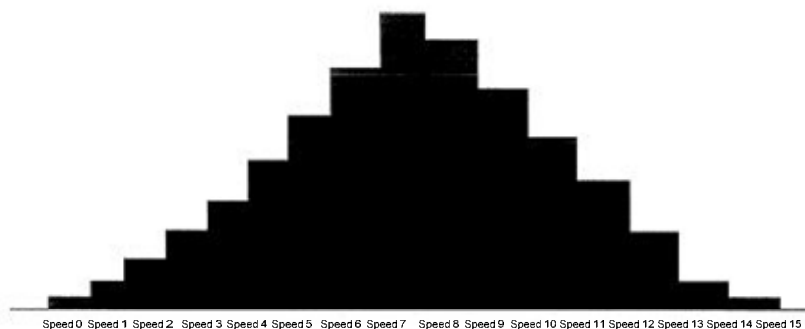

Multi-speed	Set code	Control circuit terminal				
		SW5 CF4	SW4 CF3	SW3 CF2	SW2 CF1	SW1 FW
Speed 0	F01	OFF	OFF	OFF	OFF	ON
Speed 1	A11	OFF	OFF	OFF	ON	ON
Speed 2	A12	OFF	OFF	ON	OFF	ON
Speed 3	A13	OFF	OFF	ON	ON	ON
Speed 4	A14	OFF	ON	OFF	OFF	ON
Speed 5	A15	OFF	ON	OFF	ON	ON
Speed 6	A16	OFF	ON	ON	OFF	ON
Speed 7	A17	OFF	ON	ON	ON	ON
Speed 8	A18	ON	OFF	OFF	OFF	ON
Speed 9	A19	ON	OFF	OFF	ON	ON
Speed 10	A20	ON	OFF	ON	OFF	ON
Speed 11	A21	ON	OFF	ON	ON	ON
Speed 12	A22	ON	ON	OFF	OFF	ON
Speed 13	A23	ON	ON	OFF	ON	ON
Speed 14	A24	ON	ON	ON	OFF	ON
Speed 15	A25	ON	ON	ON	ON	ON

Standard operator option code

Set the parameter [C01] ~ [C06] to [A11] ~ [A25], [F01]

Option Code	Terminal Symbol	Function Name	State	Description
Valid for inputs:		C01,C02,C03,C04,C05,C06		Example:
Required setting		F01, A11 to A25		
Notes : • When programming the multi-speed setting sure to press the Store key each time and then set the next multi-speed setting. Note that when the key is not pressed, no data will be set. • When a multi-speed setting more than 50Hz(60Hz) is to be set, it is necessary to program the maximum frequency A04 high enough to allow that speed.				

- While using the multi-speed capability, you can monitor the current frequency with monitor function [F01] during each segment of a multispeed operation. There are two ways to program the speeds into the registers [A20] to [A25]

Programming using the CF switches, Set the speed by following these steps

- (1) Turn the Run command off(Stop Mode).
- (2) Turn each switch on and set it to Multi-speed n. Display the data section of [F01].
- (3) Set an optional output frequency by pressing the ▲ and ▼ keys.
- (4) Press the (STR) key once to store the set frequency. When this occurs, [F01] indicates the output frequency of Multi-speed n.
- (5) Press the (FUNC) key once to confirm that the indication is the same as the set frequency.
- (6) When you repeat operations in (1) to (4), the frequency of Multi-speed can be set.

It can be set also be parameters [A11] to [A25]

Jogging Command [JG]

- When the terminal [JG] is turned on and the Run command is issued, the inverter outputs the programmed jog frequency to the motor. Use a switch between terminals [CM1] and [P24] to activate the JG frequency.
- The frequency for the jogging operation is set by parameter **A26**.
- Set the value **1**(terminal mode) in **A02**(Run command)
- Since jogging does not use an acceleration ramp, we recommend setting the jogging frequency in **A26** to 5Hz or less to prevent tripping.

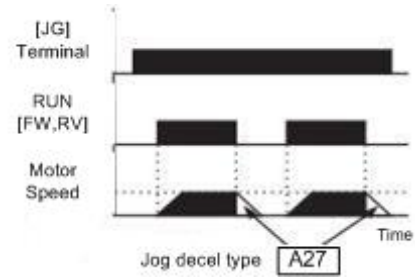

- 0:Free-run stop
- 1:Deceleration stop
- 2:DC braking stop

The type of deceleration used to end a motor jog is selectable by programming function **A27** The options are:
 0 : Free-run stop (coasting)
 1 : Deceleration (normal level) and stop
 2 : DC braking and stop

Option Code	Terminal Symbol	Function Name	Input State	Description
6	JG	Jogging	ON	Inverter is in Run Mode, output to motor runs at jog parameter frequency.
			OFF	Inverter is in Stop Mode.
Valid for inputs:		C01,C02,C03,C04,C05,C06		Example:
Required setting		A02, A26, A27		
Notes: <ul style="list-style-type: none"> • No jogging operation is performed when the set value of jogging frequency A26 is smaller than the start frequency B10 or the value is 0Hz. • Be sure to stop the motor when switching the function [JG] on or off. 				

Second Control Function [SET]

- If you assign the [SET] function to a logic terminal, the inverter will display the Sxx numbered parameters, allowing you to edit the second motor parameters. These parameters store an alternate set of motor characteristic parameters. When the terminal [SET] is turned on, the inverter will use the second set of parameters to generate the frequency output to the motor.
- When changing the state of the [SET] input terminal, first confirm the inverter is in the Stop Mode, and the motor is not rotating.
- When the switch between the set terminals [SET] and [CM1] is on, the inverter operates per the second set of parameters.
- When the terminal is turned off, the output function returns to the original settings. (first set of motor parameters.)

Option Code	Terminal Symbol	Function Name	Input State	Description
7	SET	Set 2nd Motor	ON	Causes the inverter to use the 2nd set of motor parameters for generating the frequency output to motor
			OFF	Causes the inverter to use the 1st (main) set of motor parameters for heating the frequency output to motor
Valid for inputs:		C01,C02,C03,C04,C05,C06		Example:
Required setting		(none)		
Notes:				
<ul style="list-style-type: none"> • If the terminal is turned off while the motor is running, the inverter continues to generate the frequency output using the 2nd set of parameters until the motor is stopped. 				

Two-stage Acceleration and Deceleration [2CH]

- When terminal [2CH] is turned on, the inverter changes the rate of acceleration and deceleration from the initial settings **F02** (acceleration time1) and **F03**(deceleration time1) to use the second set of acceleration / deceleration values.
- When the terminal is turned off, the equipment is turned off, the equipment is returned to the original acceleration and deceleration time (**F02** acceleration time1 and **F03** deceleration time1). Use **A54** (acceleration time2) and **A55** (deceleration time2) to set the second stage acceleration and deceleration time.
- In the graph shown above, the [2CH] becomes active during the initial acceleration. This causes the inverter to switch from acceleration 1 (**F02**) to acceleration 2 (**A54**)

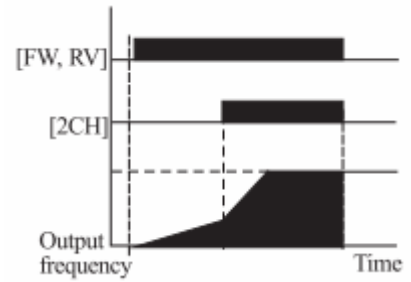

Option Code	Terminal Symbol	Function Name	Input State	Description
8	2CH	Two-stage Acceleration and Deceleration	ON	Frequency output uses 2nd-stage acceleration and deceleration values
			OFF	Frequency output uses the initial acceleration 1 and deceleration 1 values
Valid for inputs:		C01,C02,C03,C04,C05,C06		Example:
Required setting		A54, A55, A56		
Notes:		<ul style="list-style-type: none"> • Function A56 selects the method for second stage acceleration. It must be 00 to select the input terminal method in order for the 2CH terminal assignment to operate. 		

Free-run stop [FRS]

- When the terminal [FRS] is turned on, the inverter stops the output and the motor enters the free-run state (coasting).
If terminal [FRS] is turned off, the output resumes sending power to the motor if the Run command is still active.
The free-run stop feature works with other parameters to provide flexibility in stopping and starting motor rotation.
- In the figure below, parameter **B16** selects whether the inverter resumes operation from 0Hz (left graph) or the current motor rotation speed (right graph) when the [FRS] terminal turns off.
The application determines which is the best setting.
Parameter **B03** specifies a delay time before resuming operation from a free-run stop.
To disable this feature, use a zero delay time.

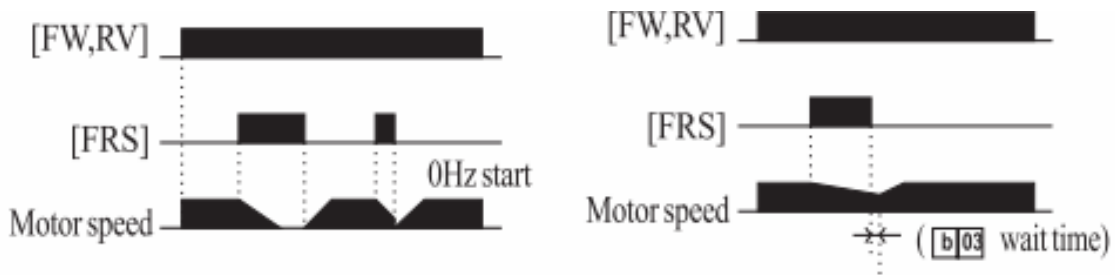

Option Code	Terminal Symbol	Function Name	Input State	Description
9	FRS	Free-run Stop	ON	Causes output to turn off, allowing motor to free run (coast) to stop
			OFF	Output operates normally, so controlled deceleration stops motor
Valid for inputs:		C01,C02,C03,C04,C05,C06		Example:
Required setting		B03, b16, C07 to C12		
Notes:				
<ul style="list-style-type: none"> When you want the [FRS] terminal to be active low (normally closed logic), change the setting (C07 to C12) which corresponds to the input (C01 to C06) that is assigned the [FRS] function 				

External Trip [EXT]

- When the terminal [EXT] is turned on, the inverter enters the trip state, indicates error code, **E12** and stop the output.
This is a general purpose interrupt type feature, and the meaning of the error depends on what you connect to the [EXT] terminal. When the switch between the set terminals [EXT] and [CM1] is turned on, the equipment enters the trip state.
Even when the switch to [EXT] is turned off, the inverter remains in the trip state.
You must reset the inverter or cycle power to clear the error, returning the inverter to the Stop Mode.

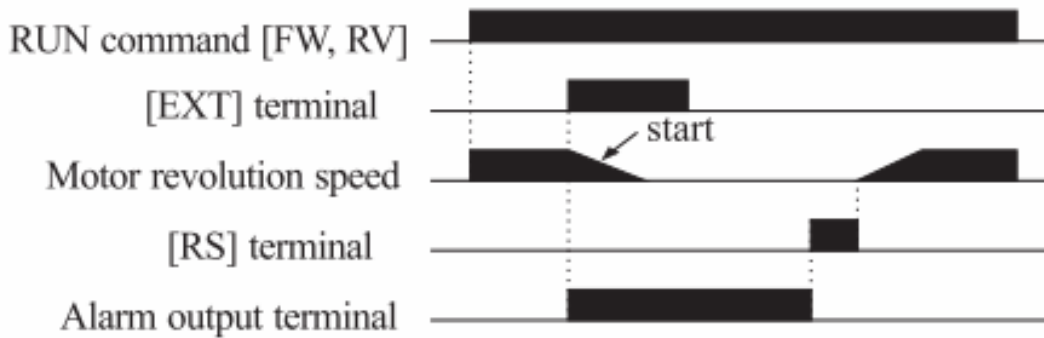

Option Code	Terminal Symbol	Function Name	Input State	Description
10	EXT	External Trip	ON	When assigned input transitions Off to On, inverter latches trip event and displays E12
			OFF	No trip event for On to Off, any recorded trip events remain in history until Reset.
Valid for inputs:		C01,C02,C03,C04,C05,C06		Example:
Required setting		(none)		
Notes:				
<ul style="list-style-type: none"> If the USP (Unattended Start Protection) feature is in use, the inverter will not automatically restart after cancelling the EXT trip event. In that case, it must receive enter Run command (off-to-on transition) 				

Unattended Start Protection [USP]

- If the Run command is already set when power is turned on, the inverter starts running immediately after power up.
The Unattended Start Protection (USP) function prevents that automatic start up, so that the inverter will not run with-out outside intervention.
To reset an alarm and restart running, turn the Run command off or perform a reset operation by the terminal[RS] input or the keypad Stop/reset key.
- In the figure below, the [UPS] feature is enabled. When the inverter power turns on, the motor does not start, even though the Run command is already active.
Instead, it enters the USP trip state, and displays E13 error code.
This forces outside intervention to reset the alarm by turning off the Run command.
Then the Run command can turn on again and start the inverter output.

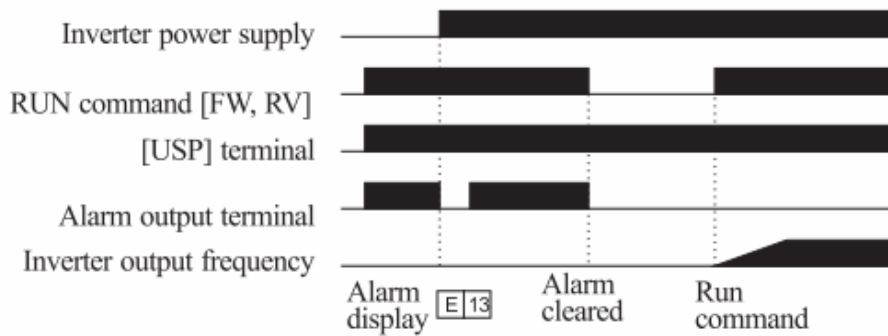

Option Code	Terminal Symbol	Function Name	Input State	Description
11	USP	Unattended start Protection	ON	On power up, the inverter will not resume a Run command (mostly used in the Us)
			OFF	On power up, the inverter will not resume a Run command that was active before power loss
Valid for inputs:		C01,C02,C03,C04,C05,C06		Example:
Required setting		(none)		
Notes: <ul style="list-style-type: none"> • Note that when a USP error occurs and it is canceled by a reset from a [RS] terminal input, the inverter restarts running immediately. • Even when the trip state is canceled by turning the terminal [RS] on and off after an under voltage protection E09 occurs, the USP function will be performed. • When the running command is active immediately after the power is turned on, a USP error will occur. When this function is used, wait for at least three seconds after the power up to generate a Run command. 				

Software Lock [SFT]

- When the terminal [SFT] is turned on, the data of all the parameters and functions except the output frequency is locked (prohibited from editing).
When the data is locked, the keypad keys cannot edit inverter parameters.
To edit parameters again, turn off the [SFT] terminal input.
Use parameter B31 to select whether the output frequency is excluded from the lock state or is locked as well.

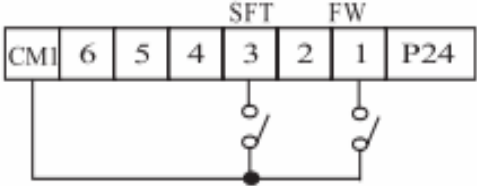
Option Code	Terminal Symbol	Function Name	Input State	Description
12	SFT	Software Lock	ON	The keypad and remote programming devices are prevented from changing parameters
			OFF	The parameters may be edited and stored
Valid for inputs:		C01,C02,C03,C04,C05,C06		Example: 
Required setting		B09 (excluded from lock)		
Notes:				
<ul style="list-style-type: none"> • When the [SFT] terminal is turned on, only the output frequency can be changed. • Software lock can be made possible also for the output frequency by b09. • Software lock by the operator is also possible without [SFT] terminal being used (b09) 				

Analog Input Current / Voltage Select [AT]

- The [AT] terminal selects whether the inverter uses the voltage [O] or current [OI] input terminals for external frequency control.
 When the switch between the terminals [AT] and [CM1] is on, it is possible to set the output frequency by applying a current input signal at [OI]-[L].
 When the terminal is turned off, the voltage input signal at [O]-[L] is available.
 Note that you must also set parameter A 01 = 1 to enable the analog terminal set for controlling the inverter frequency.

Option Code	Terminal Symbol	Function Name	Input State	Description
13	AT	Analog Input Voltage/current select	ON	Terminal OI is enabled for current input. (uses terminal L for power supply return)
			OFF	Terminal O is enabled for voltage input. (uses terminal L for power supply return)
Valid for inputs:		C01,C02,C03,C04,C05,C06		Example: 
Required setting		A01=01		
Notes: <ul style="list-style-type: none"> If the [AT] option is not assigned to any intelligent input terminal, then inverter uses the algebraic sum of both the voltage and current inputs for the frequency command(and A01=01) When using either the analog current and voltage input terminal, make sure that the [AT] function is allocated to an intelligent input terminal. Be sure to set the frequency source setting A01=01 to select the analog input terminals. 				

Reset Inverter [RS]

- The [RS] terminal causes the inverter to execute the reset operation. If the inverter is in Trip Mode, the reset cancels the Trip state. When the switch between the set terminals [RS] and [CM1] is turned on and off, the inverter executes the reset operation.

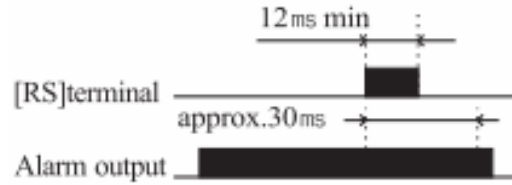

- The input timing requirement for [RST] needs a 12 ms pulse width or greater. The alarm output will be cleared within 30 ms after the onset of the Reset command.

 **DANGER**

After the Reset command is given and the alarm reset occurs, the motor will restart suddenly if the Run command is already active.
Be sure to set the alarm reset after verifying that the Run command is off to prevent injury to personnel.

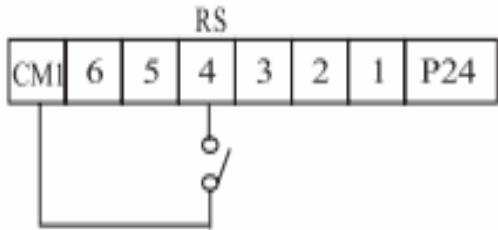
Option Code	Terminal Symbol	Function Name	Input State	Description
14	RS	Reset Inverter	ON	The motor output is turned off, the trip Mode is cleared (if it exists), and power up reset is applied
			OFF	Normal power-on operation
Valid for inputs:		C01,C02,C03,C04,C05,C06		Example: 
Required setting		(none)		
Notes:				
<ul style="list-style-type: none"> • When the control terminal [RS] input is already at power up for more than 4 seconds, the display of the digital operator is E60. However, the inverter has no error. To clear the digital operator error, turn off the terminal [RS] input and press stop/reset butt on of the operator. • When the [RS] terminal is turned off from on, the Reset command is active. • The stop/reset key of the digital operator is valid only when an alarm occurs. • Only the normally open contact [NO] can be set for a terminal configured with the [RS] function. The terminal cannot be used in the normally closed contact [NC] state. • Even when power is turned off or on, the function of the terminal is the same as that of the reset terminal. • The Stop/Reset key on the inverter is only operational for a few seconds after inverter power up when a hand-held remote operator is connected to the inverter. • If the [RS] terminal is turned on while the motor is running, the motor will be free running(coasting) 				

5.4 Using Intelligent output terminals

(Initial setting is a-contact [NO])

Frequency Arrival Signal [FA1]/[FA2]

Frequency Arrival [FA1] and [FA2] signals indicate when the output frequency accelerates or decelerates to arrive at a constant frequency. Refer to the figure below.

Frequency Arrival [FA1](upper graph) turns on when the output frequency gets within 0.5Hz below or 1.5Hz above the target constant frequency.

The timing is modified by a small 60ms delay. Note the active low nature of the signal, due to the open collector output.

Frequency Arrival [FA2] (lower graph) uses thresholds for acceleration and deceleration to provide more timing flexibility than [FA1].

Parameter C19 sets the arrival frequency threshold for acceleration, and parameter C20 sets the thresholds for deceleration.

This signal also is active low and has a 60ms delay after the frequency thresholds are crossed.

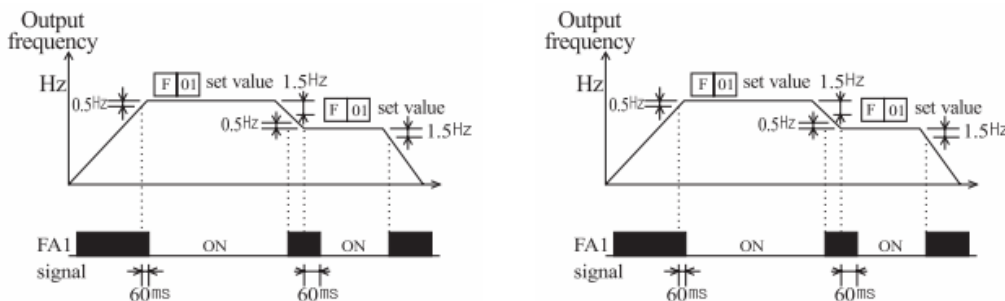

Option Code	Terminal Symbol	Function Name	Input State	Description
1	FA1	Frequency arrival type 1 signal	ON	when output to motor is at the set frequency
			OFF	when output to motor is off, or in any acceleration or deceleration ramp
2	FA2	Frequency arrival type 2 signal	ON	when output to motor is at or above the set frequency the holds for, even if in acceleration or deceleration ramps
			OFF	when output to motor is off, or during acceleration or deceleration before the respective thresholds are crossed
Valid for inputs:		C13, C14, C19, C20		
Required setting		(none)		
Notes:				
<ul style="list-style-type: none"> • At the time of acceleration, an arrival signal at a frequency between the set frequency -0.5Hz to +1.5Hz is turned on. • At the time of deceleration, an arrival signal at a frequency between the set frequency +0.5Hz to -1.5Hz is turned on. • The delay time of the output signal is 60m (nominal). 				

Run Signal [RUN]

When the [RUN] signal is selected as an intelligent output terminal, the inverter outputs a signal on that terminal when it is in the Run Mode.
 The output logic is active low, and is the open collector type (switch to ground)

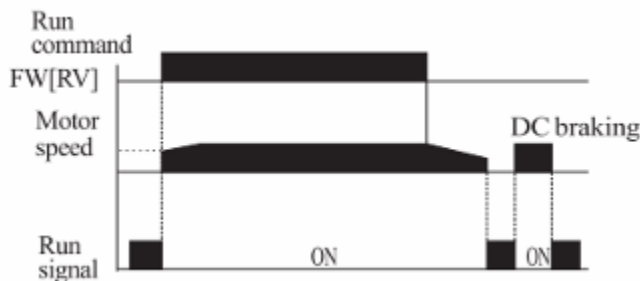

Option Code	Terminal Symbol	Function Name	Input State	Description
0	RUN	Run signal	ON	when inverter is in Run Mode
			OFF	when inverter Stop Mode
Valid for inputs:		C13		
Required setting		0		
Notes:				
<ul style="list-style-type: none"> The inverter outputs the [RUN] signal whenever the inverter output exceeds the start frequency. The start frequency is the initial inverter output frequency when it turns on. 				

The example circuit in the table above drives a relay coil. Note the use of a diode to prevent the negative-going turn-off spike generated by the coil from damaging the inverter's output transistor.

Overload Advance Notice Signal [OL]

When the output current exceeds a preset value, the [OL] terminal signal turns on. The parameter C18 sets the overload threshold. The overload detection circuit operates during powered motor operation and during regenerative braking. The output circuits use open-collector transistors, and are active low.

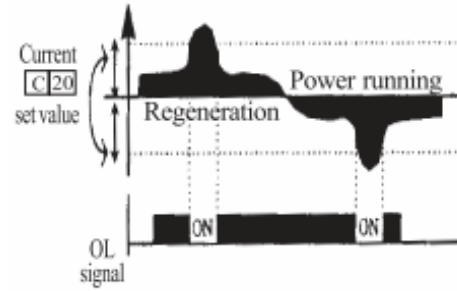

Option Code	Terminal Symbol	Function Name	Input State	Description
3	OL	Overload advance notice signal	ON	when output current is more than the set threshold for the overload signal.
			OFF	when output current is less than the set threshold for the overload signal.
Valid for inputs:		C13, C14, C18		
Required setting		3		
Notes:				
<ul style="list-style-type: none"> The default value is 100%. To change the level from the default, set C18 (overload level). The accuracy of this function is the same as the function of the output current monitor on the [FM] terminal 				

Output Deviation for PID Control [OD]

The PID loop error is defined as the magnitude(absolute value) of the difference between the Set point (target value) and the process Variable (actual value).

When the error magnitude exceeds the press value for C21, the [OD] terminal signal turns on. Refer to the PID loop operation.

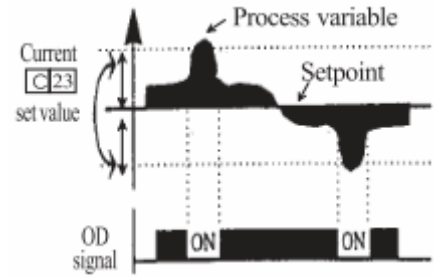

Option Code	Terminal Symbol	Function Name	Input State	Description
4	OD	Output deviation for PID control	ON	When PID error is more than the set threshold for the deviation signal
			OFF	When PID error is less than the set threshold for the deviation signal
Valid for inputs:		C13, C14, C21		
Required setting		4		
Notes:				
<ul style="list-style-type: none"> The default difference value is set to 10%. To change the value, change parameter C21. (deviation level) 				

Alarm Signal output [AL]

The Inverter alarm signal is active when a fault has occurred and it is in the Trip Mode.

When the fault is cleared the alarm signal becomes inactive.

We must make a distinction between the alarm signal [AL] and the alarm relay contacts AL0, AL1 and AL2.

The signal [AL] is a logic function which you can assign to the relay output terminal RN.

The most common (and default) use of the relay is for [AL], thus the labeling of its terminals.

Option Code	Terminal Symbol	Function Name	Input State	Description
4	OD	Alarm signal	ON	When an alarm signal has occurred and has not been cleared
			OFF	When no alarm has occurred since the last clearing of alarm(s)
Valid for inputs:		11, 12, AL0-AL2		
Required setting		C13, C14		
<p>Notes:</p> <ul style="list-style-type: none"> • When the alarm output is set to normally closed [NC], a time delay occurs until the contact is closed when the power is turned on. Therefore, when the alarm contact out-put is to be used, set a delay of about 2seconds when the power is turned on. Terminals 11 and 12 are open collector out-puts, so the electric specification of [AL] is different from the contact output terminals AL0, AL1, AL2. • See the description of AL1, AL2 and AL0. • When the inverter power supply is turned off, the alarm signal output is valid as long as the external control circuit has power. • The signal output has the delay time (300ms nominal) from the fault alarm output. • Output terminal RN is a contact a. In case of contact b, setup C14. 				

5.5 Alarm Terminal Function

Alarm Terminal [AL1, AL2-AL0]

The alarm output terminals are connected as shown below by default, or after initialization.
 The contact logic can be inverted by using the parameter setting C16.
 The relay contacts normally contact a.
 Convention uses "normal" to mean the inverter has power and is in Run or Stop Mode.
 The relay contacts switch to the opposite position when it is Trip Mode or when input power is off.

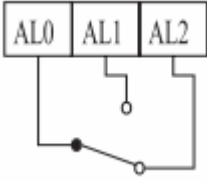
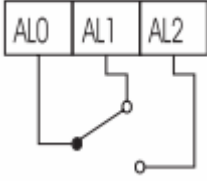
Contact a (Initial setting)																			
During normal running or power is turned off 	When an alarm occurs 																		
<table border="1" style="margin: auto; border-collapse: collapse;"> <thead> <tr> <th>Contact</th> <th>Power</th> <th>Run State</th> <th>AL0-AL1</th> <th>AL0-AL2</th> </tr> </thead> <tbody> <tr> <td rowspan="3" style="text-align: center;">Contact a (initial Setting)</td> <td style="text-align: center;">ON</td> <td style="text-align: center;">Normal</td> <td style="text-align: center;">Open</td> <td style="text-align: center;">Closed</td> </tr> <tr> <td style="text-align: center;">ON</td> <td style="text-align: center;">Trip</td> <td style="text-align: center;">Closed</td> <td style="text-align: center;">Open</td> </tr> <tr> <td style="text-align: center;">OFF</td> <td style="text-align: center;">-</td> <td style="text-align: center;">Open</td> <td style="text-align: center;">Closed</td> </tr> </tbody> </table>		Contact	Power	Run State	AL0-AL1	AL0-AL2	Contact a (initial Setting)	ON	Normal	Open	Closed	ON	Trip	Closed	Open	OFF	-	Open	Closed
Contact	Power	Run State	AL0-AL1	AL0-AL2															
Contact a (initial Setting)	ON	Normal	Open	Closed															
	ON	Trip	Closed	Open															
	OFF	-	Open	Closed															

Contact specification

Maximum	Minimum
AC250V, 2.5A(Resistor load), 0.2A(Inductive load)	AC100V, 10mA
DC30V, 3.0A(Resistor load), 0.7A(Inductive load)	DC5V, 100mA

5.6 Configuring the Inverter of Multiple Motors

Simultaneous Connections

For some applications, you may need to connect two motors (wired in parallel) to a single inverter's output. For example, this is common in conveyors applications where two separate conveyors need to have approximately the same speed. The use of two motors may be less expensive than making the mechanical link for one motor to drive multiple conveyors.

Function Name	Parameter Codes	
	1st motor	2nd Motor
Multi-speed frequency setting	F01	S01
Acceleration time setting (Acceleration 1)	F02	S02
Deceleration time setting (Deceleration 1)	F03	S03
Second acceleration time setting (Acceleration 2)	A54	S10
Second acceleration time setting (Deceleration 2)	A55	S11
Second method to use 2nd acceleration/deceleration	A56	S14
Acc1 to Acc2 frequency transition point	A57	S15
Dcc1 to Dcc2 frequency transition point	A58	S16
Acceleration patten setting	A59	S12
Dece1eration patten setting	A60	S13
Leve1 of electronic thermal setting	B04	S17
Select electronic thermal characteristic	B05	S18
Torques boost mode selection	A28	S06
Manual torque boost setting	A29	S07
Manual torque boost frequency adjustment	A30	S08
V/F characteristic curve selection	A31	S09
Base frequency setting	A03	S04
Maximum frequency setting	A04	S05
Select motor constant	H02	S19
Motor capacity setting	H03	S20
Motor poles setting	H04	S21
Motor Rated Current	H05	S22
Motor constant R1 setting (Standard, Auto tuning)	H06/H11	S23/S28
Motor constant R2 setting (Standard, Auto tuning)	H07/H12	S24/S29
Leakage inductance (Standard, Auto tuning)	H08/H13	S25/S30
Leakage factor (Standard, Auto tuning)	H09/H14	S26/S31
No load current(Standard, Auto tuning)	H10/H15	S27/S32

5.7 Sensorless Vector Control

Function description

The N700E inverter has a built-in auto-tuning algorithm. The N700E inverter can be possible to do high-starting torque and high-precision operation. Also, the settings have a second set of parameters for a second motor. The required torque characteristic or speed control characteristic may not be maintained in case that the inverter capacity is more than twice the capacity of the motor in use .

Function setting method

Select the parameter A31 to 2 (sensorless vector control).
Parameter H03 and H04 select motor capacity and poles (example 4 for 4-poles).
Parameter H02 selects which data(standard data, auto-tuning data) of motor constants you want the inverter to use.

5.8 Auto-tuning

Function description

The auto-tuning procedure automatically sets the motor parameter related to sensorless vector control. Since sensorless vector control needs motor parameter, the standard motor parameters have been set at the factory.

Therefore, when an inverter exclusive-use motor is used or when a motor of any other manufacture is drive, the motor parameter is detected by auto-tuning because the parameters are not matched.

Function setting

Follow the steps below to auto-tune the inverter, finally set the parameter H01.

F02, F03 setting : Set the time the range that over-current or over-voltage trip event not occurs.
Set the same as setting F02.

H03 setting : Set the motor rating.

0 : 220V / 2.2kW	9 : 380V / 2.2kW
1 : 220V / 3.7kW	10 : 380V / 3.7kW
2 : 220V / 5.5kW	11 : 380V / 5.5kW
3 : 220V / 7.5kW	12 : 380V / 7.5kW
4 : 220V / 11kW	13 : 380V / 11kW
5 : 220V / 15kW	14 : 380V / 15kW
6 : 220V / 18.5kW	15 : 380V / 18.5kW
7 : 220V / 22kW	16 : 380V / 22kW
8 : 220V / 30kW	17 : 380V / 30kW

H04 setting : set the motor poles

A01 setting : set the frequency command source to 0 (potentiometer)

A03 setting : set the base frequency(example 60Hz)

F01 setting : set the operation frequency except 0hz (by the potentiometer)

A53 setting : select output voltage for motor.

A33 setting : set DC braking setting to 0(disable).

H01 setting : select the auto-tuning mode (1).

After setting above parameters, press the RUN key on the standard operator.

Auto-tuning method

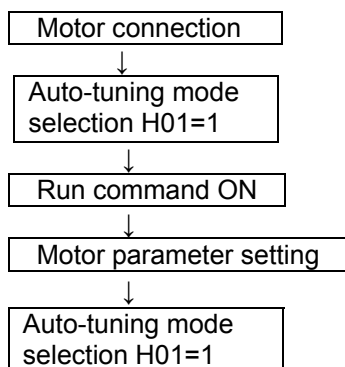

- ① DC excitation(no rotation)
- ② Single phase excitation.

End display

Auto-tuning process completed : *--oH*

Auto-tuning process failed : *Err*

Note) The motor parameter of N700E is standard data of HYUNDAI standard 4-poles motor.
 At the sensorless vector control when using different poles motor, operates by using auto-tuning data as a motor parameter.

Setting Method

(1) Digital panel

No	Name	Setting range	Description																		
H01	Auto-tuning mode selection	0/1	0 : Auto-tuning OFF 1 : Auto-tuning ON																		
H02	Motor data setting	0/1	0 : Standard data 1 : Auto-tuning data																		
H03	Motor capacity	0~17	<table> <tbody> <tr> <td>0 : 220V / 2.2kW</td> <td>9 : 380V / 2.2kW</td> </tr> <tr> <td>1 : 220V / 3.7kW</td> <td>10 : 380V / 3.7kW</td> </tr> <tr> <td>2 : 220V / 5.5kW</td> <td>11 : 380V / 5.5kW</td> </tr> <tr> <td>3 : 220V / 7.5kW</td> <td>12 : 380V / 7.5kW</td> </tr> <tr> <td>4 : 220V / 11kW</td> <td>13 : 380V / 11kW</td> </tr> <tr> <td>5 : 220V / 15kW</td> <td>14 : 380V / 15kW</td> </tr> <tr> <td>6 : 220V / 18.5kW</td> <td>15 : 380V / 18.5kW</td> </tr> <tr> <td>7 : 220V / 22kW</td> <td>16 : 380V / 22kW</td> </tr> <tr> <td>8 : 220V / 30kW</td> <td>17 : 380V / 30kW</td> </tr> </tbody> </table>	0 : 220V / 2.2kW	9 : 380V / 2.2kW	1 : 220V / 3.7kW	10 : 380V / 3.7kW	2 : 220V / 5.5kW	11 : 380V / 5.5kW	3 : 220V / 7.5kW	12 : 380V / 7.5kW	4 : 220V / 11kW	13 : 380V / 11kW	5 : 220V / 15kW	14 : 380V / 15kW	6 : 220V / 18.5kW	15 : 380V / 18.5kW	7 : 220V / 22kW	16 : 380V / 22kW	8 : 220V / 30kW	17 : 380V / 30kW
0 : 220V / 2.2kW	9 : 380V / 2.2kW																				
1 : 220V / 3.7kW	10 : 380V / 3.7kW																				
2 : 220V / 5.5kW	11 : 380V / 5.5kW																				
3 : 220V / 7.5kW	12 : 380V / 7.5kW																				
4 : 220V / 11kW	13 : 380V / 11kW																				
5 : 220V / 15kW	14 : 380V / 15kW																				
6 : 220V / 18.5kW	15 : 380V / 18.5kW																				
7 : 220V / 22kW	16 : 380V / 22kW																				
8 : 220V / 30kW	17 : 380V / 30kW																				
H04	Motor poles	2/4/6/8	Unit : pole																		
H05	Rating motor current	-	Unit : A																		
H06	Nomal motor current	0.1 – 100.0A	Unit : A																		
H07	Rating motor slip	0.01 – 10.00%	Unit : %																		
H08/H10	Motor resistor R1	0.001~30.00	Unit : Ω																		
H09/H11	Transient Inductance	0.01~100.0	Unit : mH																		

The data of H10 to H11 is auto-tuning data.

Remark

1. If satisfactory performance through auto-tuning cannot be fully obtained, please adjust the motor constants for the observed symptoms according to the table below.

Operation status	Symptom	Adjustment	Parameter
Powered running (status with a accelerating torque)	When low frequency (a few Hz) torque is insufficient.	Slowly increase the motor constant R1 in relation to auto-tuning data within 1 to 1.2 times R1.	H08/H10 /S25/S27
	When the speed deviation is negative.	Slowly increase the motor constant R2 in relation to auto-tuning data within 1 to 1.2 times R2.	H07/H12 S24/S29
	When the speed deviation is positive.	Slowly decrease the motor constant R2 in relation to auto-tuning data within 0.8 to 1 times R2.	H07/H12 S24/S29
	When over current protection is operated at injection of load.	Slowly increase the motor constant IO in relation to auto-tuning data within 1 to 1.2 times IO.	H06/S23
Regeneration (status with a decelerating torque)	When low frequency (a few Hz) torque is insufficient.	Slowly increase the motor constant R1 in relation to auto-tuning data within 1 to 1.2 times R1.	H08/H10 /S25/S27
		Slowly increase the motor constant IO in relation to auto-tuning data within 1 to 1.2 times IO.	H06/S23
		Decrease the carrier frequency.	b11



2. If the inverter capacity is more than twice the capacity of the motor in use, the inverter may not achieve its full performance specifications.
3. Running multiple motor under sensorless vector control is not available.
4. When DC braking is enabled, the motor constant will not be accurately set. Therefore, disable DC braking before starting the auto-tuning procedure.
5. The motor will rotate up to 80% of base frequency : make sure that acceleration or deceleration is not operated. If then, decrease the manual torque boost setting value.
6. Be sure if motor is in standstill before you carry out an auto-tuning. Auto-tuning data carried out when motor is still running may be not correct.
7. If the auto-tuning procedure is interrupted by the stop command, the auto-tuning constants may be stored in the inverter. It will be necessary to store the inverters factory defaults setting.

6. Protective function

The various functions are provided for the protection of the inverter itself, but they may also protection function when the inverter breaks down.

Name	Cause(s)	Error Code
Overcurrent protection	When the inverter output current exceeds the rated current by more than approximately 200% during the motor locked or reduced in speed. Protection circuit activates, halting inverter output.	E04
Overload protection (Electronic thermal) Regenerative	When the inverter output current causes the motor to overload, the electronic thermal trip in the inverter cuts off the inverter output.	E05
Over voltage protection	If regenerative energy from the motor or the main power supply voltage is high, the protective circuit activates to cut off the inverter output when the voltage of DC link exceeds the specification	E07
Communication error	The inverter output is cut off when communication in the inverter has an error to external noise, excessive temperature rise, or other factor	E60
Under-voltage protection	When input voltage drops below the low-voltage detection level, the control circuit does not function normally. So when the input voltage is below the specification, the inverter output is cut off.	E09
Output short-circuit	The inverter output was short-circuited. This condition causes excessive current for the inverter, so the inverter output is turned off.	E04 or E34
USP error	The USP error is indicated when the power is turned on with the Inverter in RUN state. (Enabled when the USP function selected)	E13
EEPROM	The inverter output is cut off when EEPROM in the inverter has an error due to external noise, excessive temperature rise, or other factor	E08
External trip	When the external equipment or unit has an error, the inverter receives the corresponding signal and cuts off the output.	E12
Temperature trip	When the temperature in the main circuit increases due to cooling fan stop, the inverter output is cut off. (only for the model type with cooling fan)	E21
Ground fault	When ground fault is detected on running condition, the output is cut off.	E14

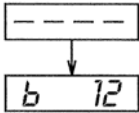
Other display

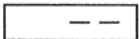
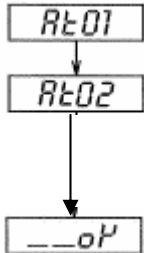
Contents	Display
<p>It is displayed when initialization of data is processing (It is not displayed when initialization of history is processing.)</p>	
<p>It is displayed when Copy function is operated by the remote operator.</p>	
<p>There is no data available (Trip history, PID feedback data)</p>	
<p>The auto-tuning operation terminates normally.</p>	

7. Troubleshooting Tips

Symptom/condition		Probable Cause	Countermeasure
The motor will not move	The inverter outputs U,V and W are not supplying voltage.	<ul style="list-style-type: none"> Is the frequency command source A01 parameter setting Correct? Is the Run command source A02 parameter setting correct? 	<ul style="list-style-type: none"> Make sure the parameter A01 setting correct? Make sure the parameter A02 setting correct?
		<ul style="list-style-type: none"> Is power being supplied to terminals R, S and T? If so, the power lamp should be on. 	<ul style="list-style-type: none"> Check terminals R, S and T then U, V, and W Turn on the power supply or check fuses.
		<ul style="list-style-type: none"> Is there an error code E□□ displayed? 	<ul style="list-style-type: none"> Press the Func key and determine the error type. Then clear the error(Reset).
		<ul style="list-style-type: none"> Are the signals to the intelligent input terminals correct? Is the Run Command active? Is the[FW] terminal (or [RV] connected to CM1(via switch, etc.) 	<ul style="list-style-type: none"> Verify the terminal functions for C01-C06 are correct. Turn on Run Command Supply 24V to [FW] or [RV] terminal, if configured. (Terminal mode selection)
		<ul style="list-style-type: none"> Has the frequency setting for F01 been set greater than zero? Are the control circuit terminals H, O, and L connected to the potentiometer? 	<ul style="list-style-type: none"> Set the parameter for F01 to a safe, non-zero value. If the potentiometer is the frequency setting source, verify voltage at "O" >0V
	<ul style="list-style-type: none"> Is the RS(reset) function or FRS (free-run stop) function on? 	<ul style="list-style-type: none"> Turn off the command(s) 	
Inverter outputs U,V,W are supplying voltage.	<ul style="list-style-type: none"> Is the motor load too heavy? Is the motor locked? 	<ul style="list-style-type: none"> Reduce load, and test the motor independently. 	
The direction of the motor is reversed	<ul style="list-style-type: none"> Are the connections of output terminal U, V, and W correct? Is the phase sequence of the motor forward or reverse with respect to U, V, and W? 	<ul style="list-style-type: none"> Make connections according to the phase sequence of the motor. In general : FWD=U-V-W, and REV=U-W-V. 	
	<ul style="list-style-type: none"> Are the control terminals [FW] and [RV]wired correctly? Is parameter F04 properly set? 	<ul style="list-style-type: none"> Use terminal [FW] for [RV] is reverse. Set motor direction in F04. 	
The motor speed will not reach the target frequency (desired speed)	<ul style="list-style-type: none"> If using the analog input, is the current or voltage at "O" or "OI"? 	<ul style="list-style-type: none"> Check the wiring Check the potentiometer or signal generating device. 	
	<ul style="list-style-type: none"> Is the load too heavy? 	<ul style="list-style-type: none"> Reduce the load. Heavy loads activate the overload restriction feature. (reduces output as needed) 	
The rotation is unstable	<ul style="list-style-type: none"> Is the load fluctuation too great? Is the supply voltage unstable? Is the problem occurring at a particular frequency? 	<ul style="list-style-type: none"> Increase the motor capacity (both inverter and motor) Fix power supply problem. Change the output frequency slightly, or use the jump frequency setting to skip the problem frequency. 	
The RPM of the motor does not match the inverter output frequency setting	<ul style="list-style-type: none"> Is the maximum frequency setting A04 correct? Does the monitor function d01 display the expected output frequency? 	<ul style="list-style-type: none"> Verify the V/F settings match motor specifications Make sure all scaling is properly set 	

Symptom/condition		Probable Cause	Countermeasure
Inverter data is not correct	No down-loads have occurred.	• Was power turned off after a parameter edit but before pressing the store key?	• Edit the data and press the store key once
		• Edits to data are permanently stored at power down. Was the time from power off to power on less than six seconds?	• Wait six seconds or more before turning power off after editing data.
A parameter will not change after an edit (reverts to old setting)	The frequency setting will not change. Run/Stop does not operate.	• Was the standard operator mode and terminal mode changed correctly?	• Make sure the setting mode of [A01], [A02] is changed
	True for all parameters.	• If you're using the [SET] intelligent input selection [b09] is the [SFT] • Is switch 4 (located on the back of the remote operator copy unit) on?	• Change the state of the SFT input, and check the b09 parameter. (b09=0) • Turn the switch off

Precautions for data setting

When changing any set data and pressing **STR** key to store the data, keep the equipment un-operated for 6 seconds or more after the selected method is executed.

When any key is pressed, or the reset operation is performed, or the power is turned off within 6 seconds, correct data may not be set.

8. Maintenance and Inspection

Please read following safety messages before troubleshooting or performing maintenance on the inverter and motor system.

DANGER

- Wait at least five(5) minutes after turning off the input power supply before performing maintenance of an inspection.
Otherwise, there is the danger of electric shock.

- Make sure that only qualified personnel will perform maintenance, inspection, and part replacement. (Before starting to work, remove any metallic objects from your person (wristwatch, bracelet, etc.))
Be sure to use tools with insulated handles.
Otherwise, there is a danger of electric shock and/or injury to personnel.

8.1 General Precautions and Notes

- Always keep the unit clean so that dust of other foreign matter does not enter the inverter.
- Take special care in regard to breaking wires of making connection mistakes.
- Firmly connect terminals and connectors.
- Keep electronic equipment away from moisture and oil. Dust, steel filings and other foreign matter can damage insulation, causing unexpected accidents, so take special care.
- When removing connectors, never pull the wires(wires for the cooling fan and logic P.C. board.)
Otherwise, there is danger of fire due to wire breakage and/or injury to personnel.

8.2 Inspection Items

- (1) Daily inspection
- (2) Periodic inspection(approximately once a year)
- (3) Insulation resistance test(approximately once two years)

Conduct the insulation resistance test by short circuiting the terminals as shown below.

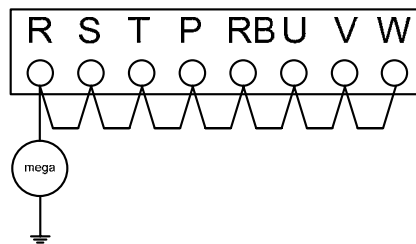

- Never test the withstand voltage on the inverter.
The inverter has a surge protector between the main circuit terminals and the chassis ground.

We recommend that you stock spare parts to reduce down time, which include

Spare parts

Part description	Symbol	Quantity		Note
		Used	Spare	
Cooling FAN	FAN	2	2	2
Case		1	1	Front case Main case Bottom cover

- Monthly and Yearly Inspection Chart

Item Inspected		Check for...	Inspection Cycle		Inspection Method	Criteria
			Month	Year		
Overall	Ambient environment	Extreme temperatures & humidity	√		Thermometer, hygrometer	Ambient temperature between -10 to 40°C, non-condensing
	Major devices	Abnormal vibration noise	√		Visual and aural	Stable environment for electronic controls
	Power supply insulation	Voltage tolerance	√		Digital volt meter, measure between inverter terminals R, S, T	200V class: 200 to 240V 50/60Hz 400V class: 380 to 480V 50/60Hz
Main circuit	Ground Insulation	Adequate resistance		√	Digital volt meter, GND to terminals	500V class Megohm meter
	Mounting	No loose screws		√	Torque wrench	M3: 0.5 ~ 0.6Nm M4: 0.98 ~ 1.3Nm M5: 1.5. ~ 2.0Nm
	Components	Overheating		√	Thermal trip events	No trip events
	Housing	Dirt, dust		√	Visual	Vacuum dust and dirt
	Terminal block	Secure connections		√	Visual	No abnormalities
	Smoothing capacitor	Leaking swelling	√		Visual	No abnormalities
	Relay(s)	Chattering		√	Aural	Single click when switching On or Off
	Resistors	Cracks or discoloring		√	Visual	Use Ohm meter to check braking resistors
	Cooling FAN	Noise		√	Power down, manually rotate	Rotation must be smooth
Dust			√		Vacuum to clean	
Control circuit	Overall	No odor, discoloring corrosion		√	Visual	No abnormalities
	Capacitor	No leaks or deformation	√		Visual	Undistorted appearance
Display	LEDs	Legibility	√		Visual	All LED segments work

Note1: The life of a capacitor is affected by the ambient temperature.

Note2: The inverter must be cleaned periodically. If dust accumulates on the fan and heat sink, it can cause overheating of the inverter.

8.3 General Inverter Electrical Measurements

The following table specifies how to measure key system electrical parameters. The diagrams on the next page show inverter-motor systems the location of measurement points for these parameters.

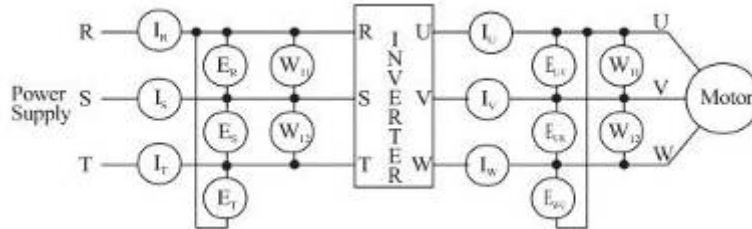

Parameter	Circuit location of measurement	Measuring instrument	Notes	Reference Value
Supply voltage E ₁	R-S, S-T, T-R (E _R) (E _S) (E _T)	Moving-coil type voltmeter or rectifier type voltmeter	Fundamental wave effective value	Commercial supply voltage (200V class) 200-220V 5Hz 200-240V 6Hz (400Vclass)
Supply current I ₁	R, S, T, Current (I _R) (I _S) (I _T)	Moving-coil type Ammeter	Total effective value	380-415V 5Hz 400-480V 6Hz
Supply power W ₁	R-R, S-T간 (W ₁₁) + (W ₁₂)	Electronic type wattmeter		
Supply power factor P _{f1}	Calculate the output power factor from the output voltage E ₁ , output current I ₁ , and output power W ₁ $P_{f1} = \frac{W_1}{\sqrt{3} \cdot E_1 \cdot I_1} \times 100(\%)$			
Output voltage E ₀	U-V, V-W, W-U (E _U) (E _V) (E _W)	Rectifier type voltmeter	Total effective value	
Output current I ₀	U, V, W Current (I _U) (I _V) (I _W)	Moving-coil type Ammeter	Total effective value	
Output power W ₀	U-V, V-W (W ₀₁) + (W ₀₂)	Electronic type wattmeter	Total effective value	
Output power factor P _{f0}	Calculate the output power factor from the output voltage E ₀ , output current I ₀ , and output power W ₀ $P_{f0} = \frac{W_0}{\sqrt{3} \cdot E_0 \cdot I_0} \times 100(\%)$			

Note 1: Use a meter indicating a fundamental wave effective value for voltage, and meters indicating total effective values for current and power.

Note 2: The inverter output has a PWM waveform, and low frequencies may cause erroneous readings.

However, the measuring instruments and methods listed above provide comparably accurate results.

Note 3: A general-purpose digital volt meter (DVM) is not usually suitable to measure a PWM waveform (not pure sinusoid)

9. RS485 Communication

The communication between inverter and external controller is doing by RS485 using modular connector in cling to inverter controller.

Function code	Minimum	Maximum	Initial Value	Unit	Description
b17	1	32	1	-	Setting the communication number
A01	0	3	0	-	3 : Communication
A02	0	2	0	-	2 : Digital operator

Item	Description	Remark
Interface	RS485	
Communication method	Half duplex	
Communication speed	9600	Fixing
Communication code	Binary code	
Data bits	8	Fixing
Parity	No.	Fixing
Stop bit	1	Fixing
Starting method	External request	Inverter is only slave part.
Wait time	10~1000ms	
Connection type	1 : N (Max32)	
Error check	Frame / CRC / CMD / MAXREQ / parameter	Communication number is selected at b17

RS485

DOP	RXP	RXN	CM1
24V	Transmit/Receive +side	Transmit/Receive -side	24V GND

Communication sequence

The communication sequence is as follows

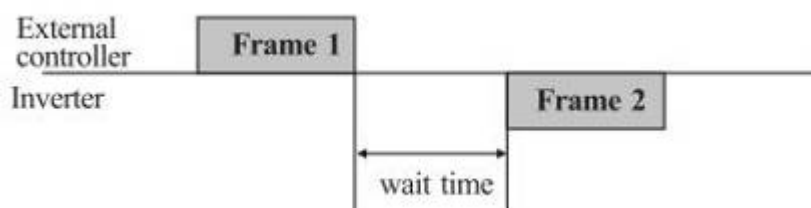

Frame start : Frame start is recognized by signal line data transmitted.

Frame completion : Frame completion is recognized by no data during correspond 4, 5-character time.

Frame 1: Transmit from external controller to inverter.

Frame 2: Indication reflects from inverter to external controller

Communication frame type and form

External controller transmit frame

Communication number	Command	Parameter	Parameter Count	CRC Hi	CRC Lo
----------------------	---------	-----------	-----------------	--------	--------

	Description	Data size	Specifications
Communication number	Inverter Communication number	1 byte	1~32
Command	Frame type	1 byte	0x06
Parameter	Parameter	2 byte	1 st byte : Group 2 nd byte : Index (note1)
Parameter number	Request parameter number	2 byte	1 st byte : 0x00 2 nd byte : N(0x01~0x08)
CRC Hi	-	1 byte	Higher 8bit of 16bit CRC
CRC Lo	-	1 byte	Lower 8bit of 16bit CRC

Inverter response frame

Communication number	Order	Byte Number	Data 1	Data N	CRC Hi	CRC Lo
----------------------	-------	-------------	--------	-------	--------	--------	--------

	Description	Data size	Specifications
Communication number	Inverter Communication number	1 byte	1~32
Command	Frame type	1 byte	0x06
Byte Number	Data Byte number	1 byte	Request parameter number x 2
Data 1	Parameter 1	2 byte	Parameter value
Data N	Parameter N	2 byte	Nth parameter value
CRC Hi	-	1 byte	Higher 8bit of 16bit CRC
CRC Lo	-	1 byte	Lower 8bit of 16bit CRC

* Frame Size = 5 + Request parameter number x 2

External transmit frame

Communication number	Order	Parameter	Data	CRC Hi	CRC Lo
----------------------	-------	-----------	------	--------	--------

	Description	Data size	Specifications
Communication number	Target Inverter Communication number	1 byte	1~32
Command	Frame type	1 byte	0x06
Parameter	Parameter	2 byte	1 st byte : Group 2 nd byte : Index (Note1)
Data	Data	2 byte	Setting value(Note 2)
CRC Hi	-	1 byte	Higher 8bit of 16bit CRC
CRC Lo	-	1 byte	Lower 8bit of 16bit CRC

Inverter response frame

Communication number	Order	Parameter	Data	CRC Hi	CRC Lo
----------------------	-------	-----------	------	--------	--------

	Description	Data size	Specifications
Communication number	Target Inverter Communication number	1 byte	1~32
Command	Frame type	1 byte	0x03
Parameter	Parameter	2 byte	1 st byte : Group 2 nd byte : Index (Note1)
Data	Data	2 byte	Setting value is response (Note4)
CRC Hi	-	1 byte	Higher 8bit of 16bit CRC
CRC Lo	-	1 byte	Lower 8bit of 16bit CRC

(Note1) Parameter setting

Basic parameter

1st byte : Each group is setting

Group	1 st byte	Group	2 nd byte
d	0x01	C	0x05
F	0x02	S	0x06
A	0x03	H	0x07
b	0x04		

2nd byte : Parameter number setting.

Ex) The case of A60 parameter reading or writing

1st byte : 0x03

2nd byte : 0x3C

Trip information

Trip information is 4 parameter.(output frequency, output current, DC link voltage at trip occurs)

	Trip Information	Previous first trip	Previous second trip	Previous third trip	Trip count
1 st byte	0x01	0x01	0x01	0x01	0x01
2 nd byte	0x0D	0x11	0x15	0x19	0x1D

Trip information items

Trip data	Trip contents	Trip data	Trip contents
1	Over current trip	7	Electric thermal trip
2	Over voltage trip	8	Outside trip
3	Under voltage trip	9	EEPROM trouble
4	Arm Short trip	10	Communication trouble
5	Reserved	11	USP trip
6	Inverter over heat trip	12	GF trip

(Note2) Data value setting

Data value is transmitted except decimal point.

Ex1) Output frequency

Parameter value	Communication data	Conversion hexadecimal
60.0Hz	6000	1 st byte : 0x17 2 nd byte : 0x70

Ex2) acc/dec time

Parameter value	Communication data	Conversion hexadecimal
10.0sec	100	1 st byte : 0x00 2 nd byte : 0x64

(Note3) Special parameter

Run command

Parameter

1st byte : 0x00

2nd byte : 0x02

setting data

1st byte

Bit7	Bit6	Bit5	Bit4	Bit3	Bit2	Bit1	Bit0
Reserved							

2nd byte

Bit7	Bit6	Bit5	Bit4	Bit3	Bit2	Bit1	Bit0
Reserved					RST	REV	FWD

Bit 0 : Forward command

Bit 1 : Reverse command

Bit 2 : Reset command

Frequency command

Parameter

1st byte : 0x00

2nd byte : 0x04

setting data

output frequency * 100

Ex) the case of output frequency command is 60.00Hz

Data 6000 transmit

1st byte : 0x17

2nd byte : 0x70

16bit CRC generation

The step of CRC generation is as follows:

1. All of 16-bit register is 1.0xffff
2. The exclusive OR of 16-bit register and 8-bit register.
3. Shift right side 1bit 16-bit register
4. If the result of step 3 is 1, exclusive OR 16-bit register and 0xa001.
5. Execute 8 times step 3 and step 4.
6. Execute step 2~6 until data completion.
7. Exchange the step 6 result of higher 8bit and lower 8bit.

Ex) The case of D01 output frequency reading.

Byte 1	Byte 2	Byte 3	Byte 4	Byte 5	Byte 6
Communication Number	Command	Parameter		Parameter number	
0x01	0x03	0x01	0x01	0x00	0x01

The sequence of addition Byte(01x01)

16-BIT REGISTER (Exclusive OR)		MSB			Flag
01	1111	1111	1111	1111	
	0000	0001			
	1111	1111	1111	1110	
Shift 1	0111	1111	1111	1111	
Shift 2	0011	1111	1111	1111	1
Polynomial	1010	0000	0000	0001	
	1001	1111	1111	1110	
Shift 3	0100	1111	1111	1111	
Shift 4	0010	0111	1111	1111	1
Polynomial	1010	0000	0000	0001	
	1000	0111	1111	1110	
Shift 5	0100	0011	1111	1111	
Shift 6	0010	0001	1111	1111	1
Polynomial	1010	0000	0000	0001	
	1000	0001	1111	1110	
Shift 7	0100	0000	1111	1111	
Shift 8	0010	0000	0111	1111	1
Polynomial	1010	0000	0000	0001	
	1000	0000	0111	1110	

Byte 1~6	CRC of operation results
0x01	0x807e
0x03	0x3364
0x01	0x30e1
0x01	0x8831
0x00	0xd449
0x01	0x36d4

Change upper and lower 8 bit of result 0x36d4 : 0xd436

Byte7 : Upper 8 bit of CRC = 0xd4

Byte8 : Lower 8 bit of CRC = 0x36

10. Specification

10.1 Standard specification list

(1) 200V Class Specifications

Inverter Model		N700E-055LF	N700E-075LF	N700E-110LF	N700E-150LF	N700E-185LF	N700E-220LF
Max. Applicable motor (4P, kW) (Note2)		5.5	7.5	11	15	18.5	22
Rated capacity (kVA)	200V	8.3	11.1	15.6	22.2	26.3	31.2
	240V	10.0	13.3	18.7	26.6	31.6	37.4
Rated input voltage		Three-phase(3-wires) 200~240V±10%, 50/60Hz±5%					
Rated output voltage (Note3)		Three-phase 200~240V (corresponding to input voltage)					
Rated output current (A)		24	32	45	64	76	90
Dynamic braking approx. % torque, short time stop	Regenerative control	BRD circuit built-in (The discharge resistance is optional)					
	Min. resistive to be connected (Ω)	17	17	17	8.7	6	6
Weight (Kg)		4.2	4.5	4.5	6.5	7.5	8

(2) 400V Class Specifications

Inverter Model		N700E-055HF	N700E-075HF	N700E-110HF	N700E-150HF	N700E-185HF	N700E-220HF
Max. Applicable motor (4P, kW) (Note2)		5.5	7.5	11	15	18.5	22
Rated capacity (kVA)	380V	7.9	10.5	15.1	21.1	25.0	29.6
	480V	10.0	13.3	19.1	26.6	31.6	37.4
Rated input voltage		Three-phase(3-wires) 380~480V±10%, 50/60Hz±5%					
Rated output voltage (Note3)		Three-phase 380~480V (corresponding to input voltage)					
Rated output current (A)		12	16	23	32	38	45
Dynamic braking approx. % torque, short time stop	Regenerative control	BRD circuit built-in (The discharge resistance is optional)					
	Min. resistive to be connected (Ω)	70	50	50	30	20	20
Weight (Kg)		4.2	4.5	4.5	7	7	7.5

(3) Common specification for 200V/400V class

Inverter model		Common specification for all model	
Control system		Space vector modulation PWM system	
Output frequency range		0.01 ~ 400Hz	
Frequency accuracy		Digital command $\pm 0.01\%$ for Max. frequency, analog frequency $\pm 0.1\%$ (25 $\pm 10^\circ\text{C}$)	
Frequency resolving power		Digital setting : 0.01HZ, Analog setting : Max. frequency / 1,000	
Voltage/frequency characteristic		V/f control (constant torque, reduced torque), free V/f control	
Overload current rate		150%, 60sec	
Acceleration/Deceleration		0.01 ~ 3000.0 sec (Director, curve setting)	
DC Braking		On starting and decelerating by stop command, inverter operates under operation setting frequency. Or inverter operates with external input (Breaking power, time, frequency can be set.)	
Input Signal	Frequency	Operator Extend signal	Setting by up/down key Input voltage : DC0 ~ +10V (Input impedance 10K Ω) Input current : 4 ~ 20mA (Input impedance 250 Ω)
	Run/Stop	Operator Extend signal	Run / Stop key (Forward / Reverse function mode) Forward run / stop (1a connect, 1b selection possibility)
	Intelligent input terminal		FW(Forward), RV(Reverse), CF1~4(Multi-speed bit 1~4), RS(reset), AT(Analog input change), USP(USP function) EXT(external trip), FRS(freerun stop), JG(jogging), SFT(software lock), 2CH(2 nd acceleration), SET2(2 nd control)
Output Signal	Intelligent output terminal		RUN(run status signal), FA1 (frequency arrival signal), FA2 (setting Frequency arrival signal), OL(overload advance notice signal), OD(PID error deviation signal), AL(alarm signal)
	Frequency monitor		Analog meter (DC0~10V full scale. Max · 1mA) Output frequency, output current and output voltage
	Alarm output contact		OFF for inverter alarm(normally closed contact output) (Transition to ON for alarm)/Intelligent output Terminal
Other functions		AVR function, curved accel./decel. profile, upper and lower limiters, 16-stage speed profile, fine adjustment of start frequency, carrier frequency change (0.5 to 16Khz), frequency jump, gain and bias setting, process jogging, electronic thermal level adjustment, retry function, trip history monitor, 2nd setting selection, auto tuning, V/f characteristic selection, automatic torque boost, frequency conversion display, USP function	
Protection function		Over current, Over load(Electronic thermal), Over voltage, Communication error, Under voltage, Output short circuit detection, USP error, EEPROM error, External error, Ground fault, Over heat	

Standard specification	Ambient temperature	-10~50℃ (If ambient temperature is above 40℃, Carrier frequency should be lower than 2.0kHz)
	Storage temperature	-20~60℃
	Ambient humidity	Below 90%RH (Installed with no dew condensation)
	Vibration	5.9m/s ² (0.6G). 10~55Hz
	Location	Under 1000m above sea level, indoors (Installed away from corrosive gasses dust)
Option	Noise filter , DC reactor, AC reactor Remote operator, cable for remote operator, Braking resistor	

Footnotes for the preceding tables

1. The protection method conforms to JEM 1030.
2. The applicable motor refers to HYUNDAI standard 3-phase motor (4-pole). To use other motors, care must be taken to prevent the rated motor current(50/60Hz) from exceeding the rated output current of the inverter.
3. The output voltage decreases as the main supply voltage decreases (except for use of the AVR function). In any case, the output voltage cannot exceed the input power supply voltage.
4. To operate the motor beyond 50/60Hz, consult the motor manufacturer about the maximum allowable rotation speed.
5. The braking torque via capacitive feedback is the average deceleration torque at the shortest deceleration (stopping from 50/60Hz as indicated). It is not continuous regenerative braking torque. And, the average deceleration torque varies with motor loss. This value decreases when operating beyond 50 Hz. If a large regenerative torque is required, the optional regenerative braking resistor should be used.
6. Control method setting A31 to 2 (sensorless vector control) Selected, set carrier frequency setting b11 more than 2.1kHz..

10.2 Dimension

(1) N700E-055LF/055HF, N700E-075LF/075HF, N700E-110LF/110HF model external dimension.(mm)

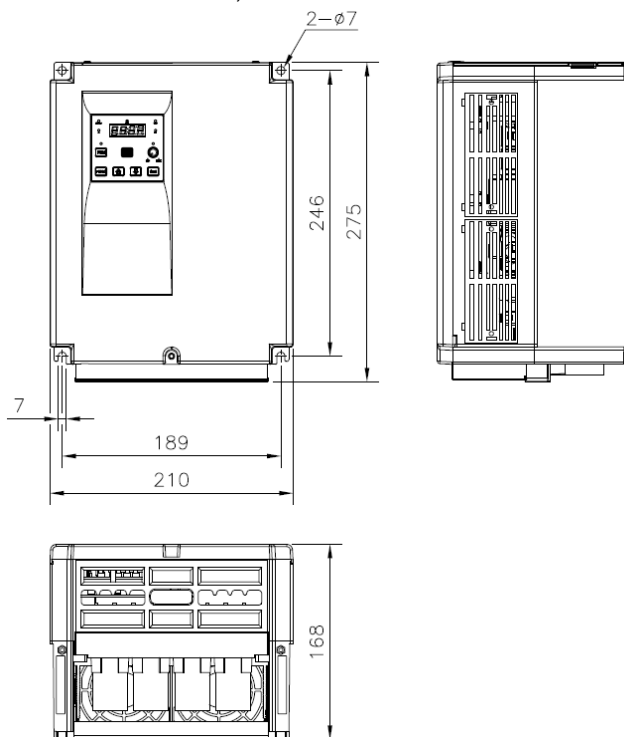

(2) N700E-150LF/150HF, N700E-185LF/185HF, N700E-220LF/220HF model external dimension.(mm)

