

HYUNDAI CLEAN-POWER
MV INVERTER *hi*RUN **N5000**



HiRUN N5000

MEDIUM VOLTAGE INVERTER

- ▶ High performance and efficiency ◀
- ▶ Supplies of clean power for motors ◀
- ▶ Small footprint and economical maintenance ◀

Model Name Indication



C O N T E N T S

Features	04
Circuit Configuration	09
Specifications	10
Outline and Dimensions	11
Components (6.6kV)	14
Connection	15
Form for Quotation	15

We build a better future!

CLEAN HYUNDAI INVERTER POWER!

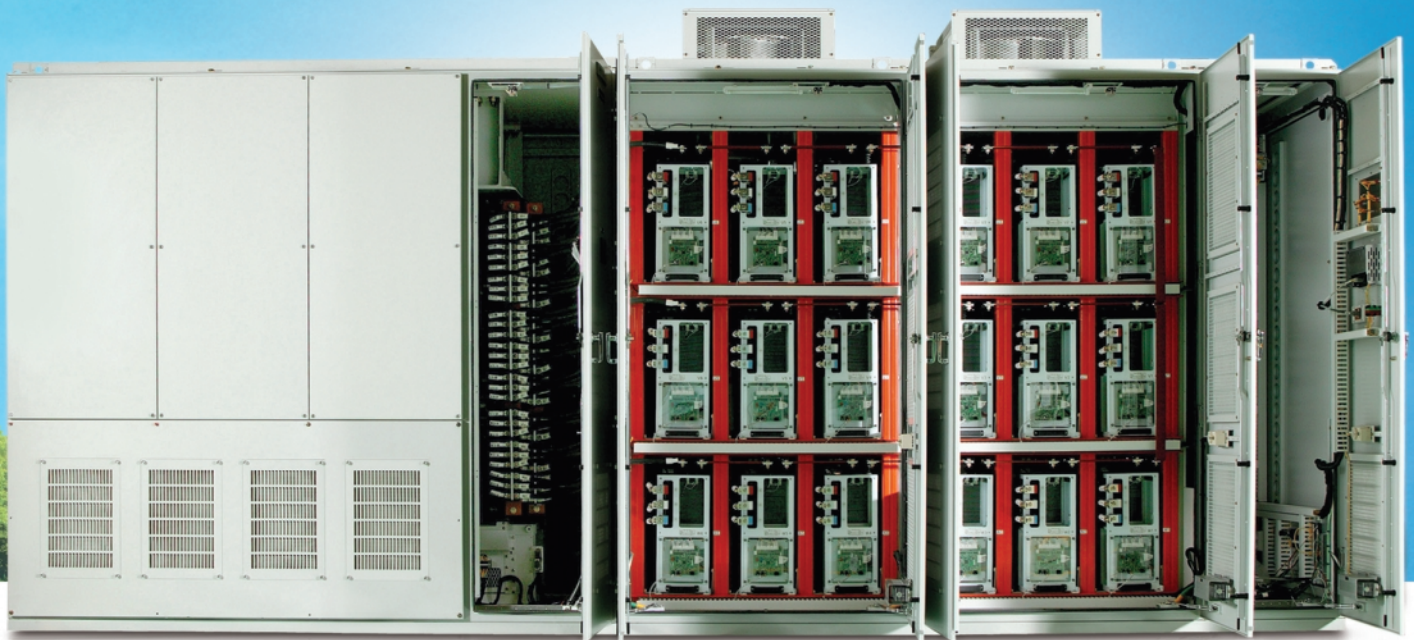

Features

High Performance and Efficiency

► **Power Factor: over 0.95**

No requirements for power factor correction capacitor

► **System Efficiency: over 96%**

System efficiency is improved by connecting the power and motor without input-output filter and output transformer

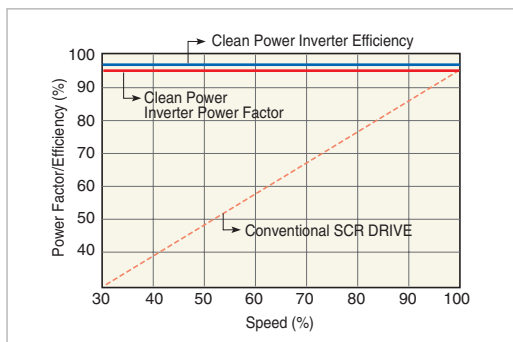

Clean Power Input

- A clean input wave is achieved via a secondary phase-shifted transformer
- Without a filter, N5000 meets the stringent harmonic requirements of IEEE-519 (1992)
- Protects the other equipment from harmonic disturbance

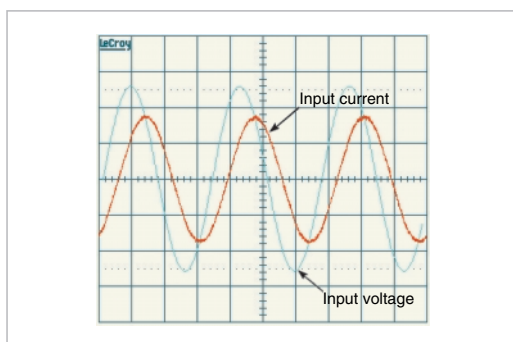

Supplies of Clean Power for Motors

- Output waveforms, without a filter, are close to sine waves due to multiple PWM control
 - No cable length & motor type restrictions
 - Existing motor can be used without modifications
 - Reduced noise and vibration of motors
- 3.3kV - 13 level/6.6kV - 25 level output

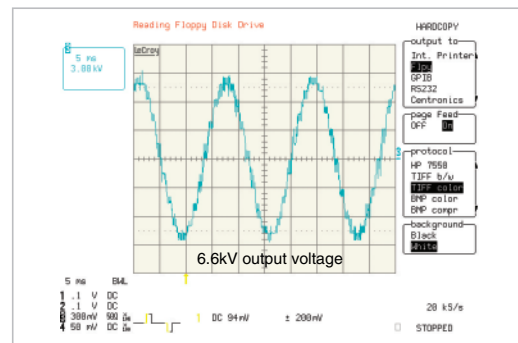

Small Footprint and Economical Maintenance

- Small footprint and reduced installation costs due to no requirements for ancillary equipments such as input & output filter and the integral structure incorporating the input transformer and inverter panel
- Thanks to the modularized single-phase inverter of draw-out type, easy maintenance and time saving are achieved.

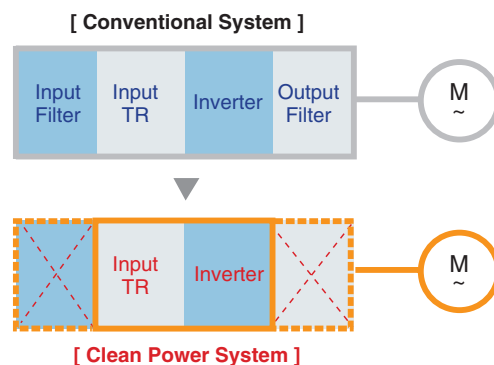

Outstanding Operation Features by the Improved Sensorless Vector Control

- ▶ Energy saving V/F control for the fluid load (Fan, Pump)
- ▶ Inherent speed sensorless vector control of N5000
 - High starting torque operation
 - Control of current, speed and vibration of motor at the low speed range of light duty
 - Quick torque responsiveness and improved speed precision
 - Strong control regardless of motor specifications

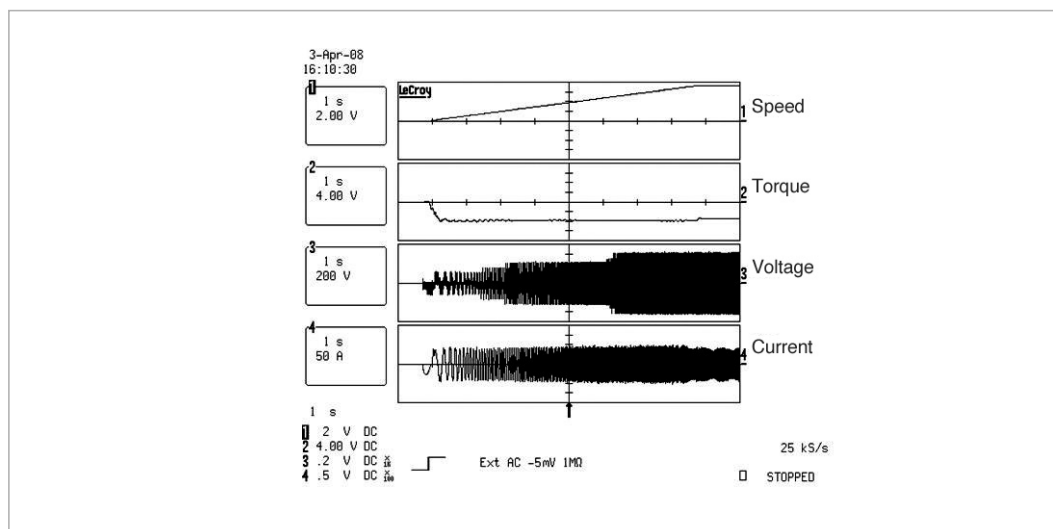
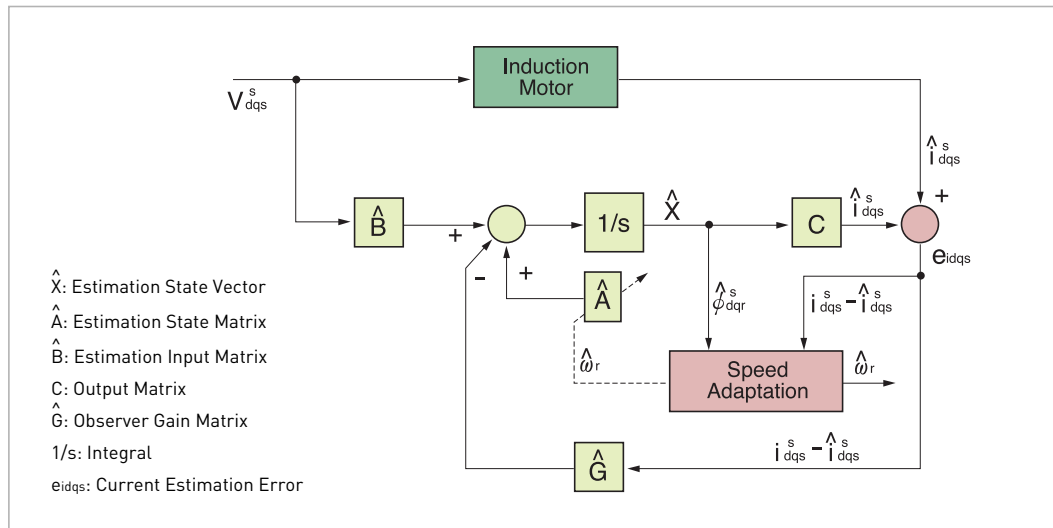

- ▶ Much more improved vector control functions can be achieved if the encoder is installed *(Option)*.

Features

Functions for Trip-Free Operation (Option)

► Improved Cell Bypass

In case of cell failure during operation, the faulty cell will be bypassed and the neutral point will be shifted (balance is restored through angle adjustment).

92% of the rated voltage can be output after the failure of one cell.

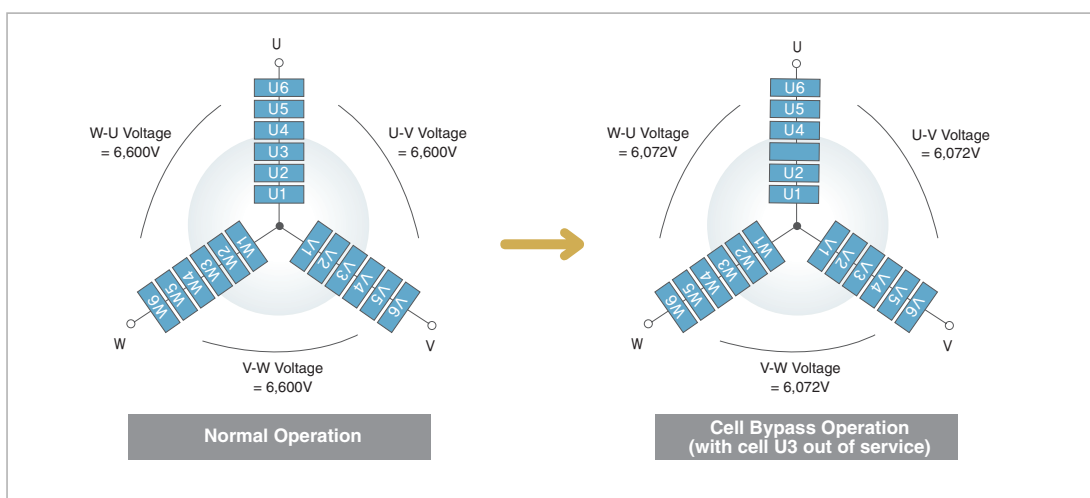

► Redundant Inverter Controller

If the master controller is out of service during operation, output is generated due to automatic switching to the slave controller

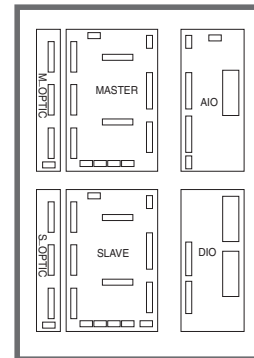
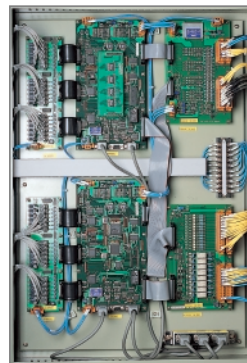

► Redundant Fiber-Optic Cable for CAN Communication

If there are problems with the optic cable during operation, an automatic switching to the standby reserve optical communication H/W is made

► Redundant Control Power

The redundant control power module is equipped with AC 440V and DC 120V and monitors the control power. In case of the failure of a control power module, an automatic switching to the reserve module is made

► Inverter Operator with Convenient Functions (Color LCD)

Easy Touch Key Settings

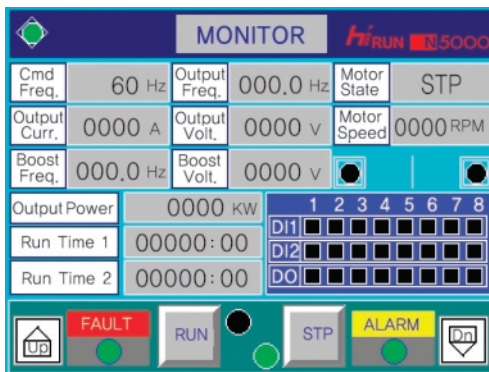
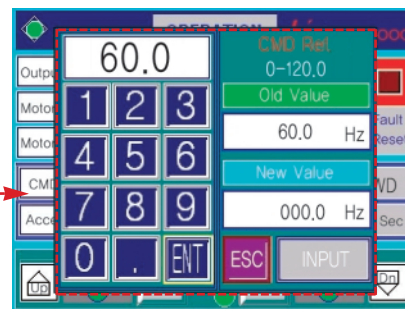
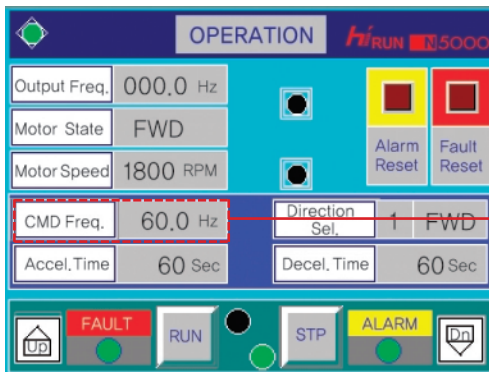

Inverter Operation Status Display

- Operation frequency, input-output voltage, output current
- Input-output of external signals
- Warning status

Inverter Fault Display

- Fault type
- Time of Fault
- Operating frequency at time of fault
- Voltage and current at time of fault

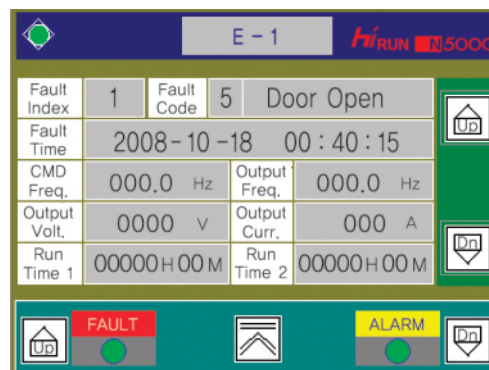

Features

Optional User Friendly PC-based Console (Option)

- ▶ Remote operation and monitoring via laptop or desktop
- ▶ Easy parameter setting and monitoring
- ▶ Multiple communication interfaces (RS-232, RS-485, MODBUS)
- ▶ Custom-made MMI display and upgrade support

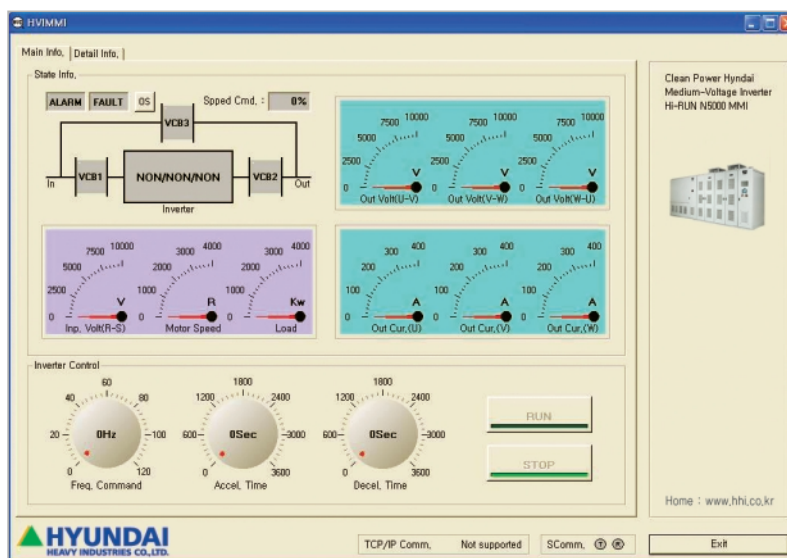

▶ Display of Detailed Information

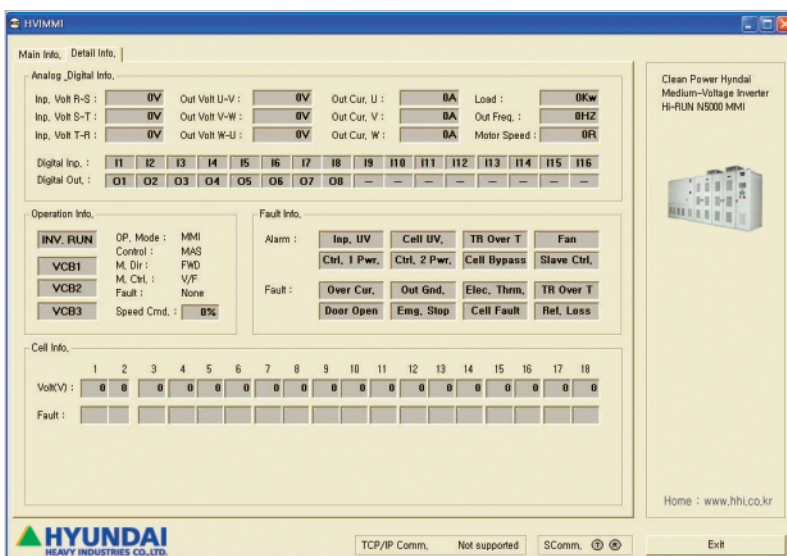

Circuit Configuration

3.3kV System Circuit Configuration

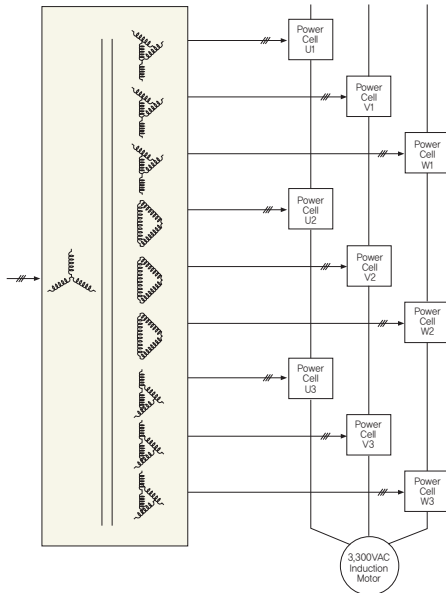

6.6kV System Circuit Configuration

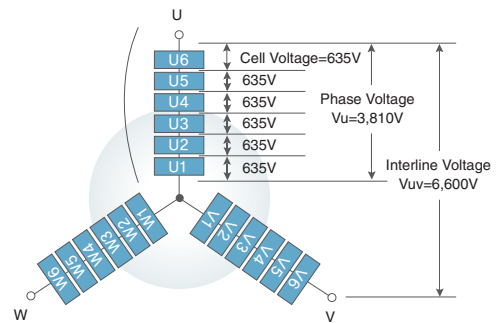
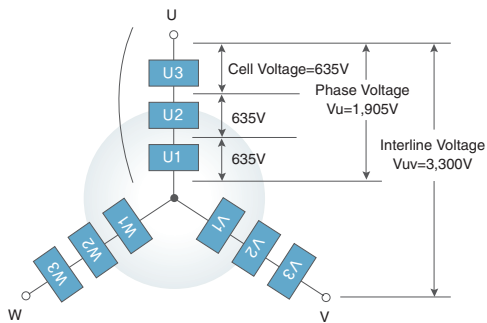
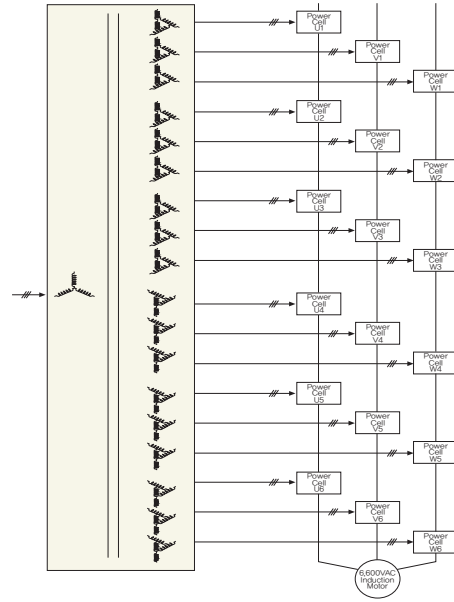

Single-phase Cell Inverter (Power Cell)

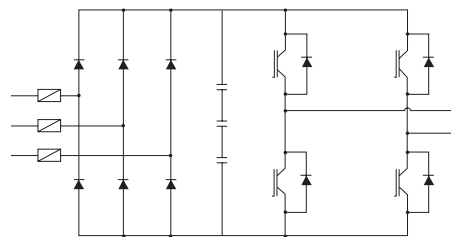

Specifications

Voltage class		3300V ¹⁾													
3.3kV output capacity (kVA)		200	300	400	500	600	750	1000	1250	1500	1750	2000	2250	2700	3000
Rated output current (A)		35	53	70	88	105	132	175	219	263	307	350	394	473	525
Motor power output (kW) ²⁾		155	245	325	410	490	620	835	1040	1270	1500	1710	1940	2250	2500
Voltage class		4160V ¹⁾													
4.16kV output capacity (kVA)		250	380	500	640	750	950	1250	1550	1900	2200	2500	2850		
Rated output current (A)		35	53	70	89	105	132	174	216	264	306	347	396		
Motor power output (kW) ²⁾		205	310	410	530	630	790	1040	1310	1630	1900	2160	2460		
Voltage class		6600V ¹⁾													
6.6kV output capacity (kVA)		400	600	800	1000	1200	1500	2000	2500	3000	3500	4000	4500	5400	6000
Rated output current (A)		35	53	70	88	105	132	175	219	263	307	350	394	473	525
Motor power output (kW) ²⁾		330	495	675	835	1000	1270	1700	2130	2590	3020	3450	3930	4500	5000
Output	Output frequency range (Hz)	0-120Hz													
	Overload capacity	120%, 60 sec													
Input	Main circuit	3-phase 3300V, 50/60Hz, 3-phase 4160V, 50/60Hz, or 3-phase 6600V, 50/60Hz													
	Control circuit	3-phase 220V or 440V, 50Hz or 60Hz													
	Tolerance	Voltage: $\pm 10\%$, Frequency: $\pm 5\%$													
Power factor of main power supply		Approx 95% or more at normal operating speed													
Efficiency		Approx 96% (Including transformer)													
Control specification	Control method	Sensorless vector control + Multi-level sinusoidal PWM (Pulse Width Modulation)													
	Frequency precision	$\pm 0.5\%$ of maximum output frequency (Analog input)													
	Torque characteristics of load	Square torque load, Constant torque load													
	Acceleration/deceleration time	0.1~3600 sec (depend on GD ² of load machine)													
	Main control function	Soft stall (Automatic load reduction control during overload), Ride-through function (0-83ms, non-torque control), specific frequency evasion function, total run time display function, non-stop operation during speed reference loss, multiple Acc./Dcc. rate setting													
	Main protective function	Current limit, overcurrent, overvoltage, overload, undervoltage, ground fault, CPU error, cooling fan abnormal, control power abnormal													
Operation board	Data transmission	2ea among RS485/232/modbus (standard), ethernet, profibus-DP <i>Option</i>													
	Display	Color LCD graphic display: Color TFT touch method 5 inch LCD													
	Control method	Start, stop, reset fault, interlock (Emergency stop)													
Signal interface	Analog	Input: 4 channel (DC 0-10V or DC 4-20mA) Output: 4 channel (DC 0-10V or DC 4-20mA)													
	Digital	Input: 16 channel (Dry contact) Output: 8 channel (Dry contact: AC 250V 5A or DC 30V 5A)													
Main reliability function <i>(Option)</i>	Cell bypass	If an inverter cell functions abnormally, continuous operation is possible via reduced power output													
	Control device redundancy	When main control device is abnormal, auxiliary control device is communicated with optical signal transmitter													
	Control power redundancy	In case of power failure, it is possible to continuous operation without UPS, because AC and DC can be received together for control input power													
Input transformer		Temperature class H, dry type, tapping range $\pm 5\%$, only for N5000													
Construction	Protection degree of enclosure	IP20 (IEC-529)													
	Panel construction	Free standing, front maintenance type, door handle key attached													
	Cooling	Air cooled by ventilation fans mounted on panels													
	Panel color	Munsell No. 5Y 7/1													
Ambient constructions	Ambient temperature	0-40°C													
	Humidity	Max 85% (No condensation)													
	Altitude	1000m above sea level or less													
	Vibration	0.5G or less at 10-50Hz													
	Installation	Indoors													
Applications		Fan, blower, pump, compressor, extruder, mixer etc. (Non-Regenerative devices)													
Standards		Electrical performance: IEC Components and others: KS													

※ ¹⁾ As for the non-standard voltage (3.0kV, 6.0kV) motor, please contact Hyundai Heavy Industries Co., Ltd.

²⁾ Based on Hyundai Heavy Industries Co., Ltd.'s standard squirrel type 4 pole motors

Outline and Dimensions

A Type

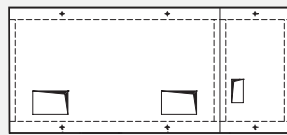
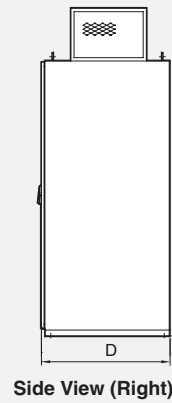
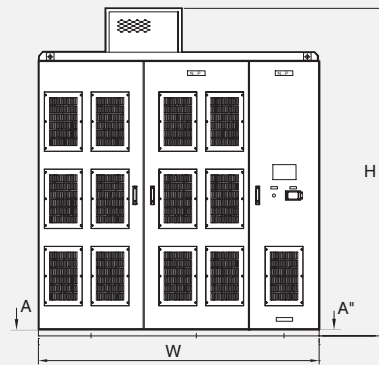

B Type

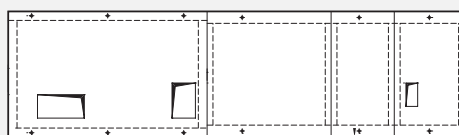
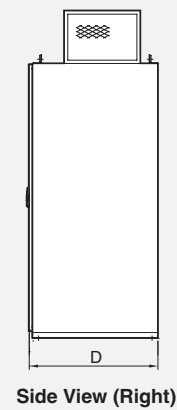
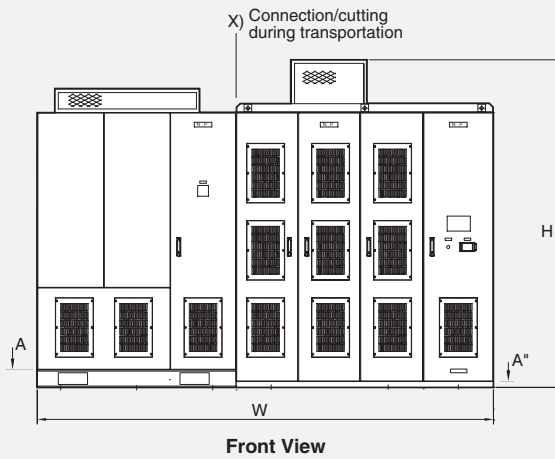

Outline and Dimensions

C Type

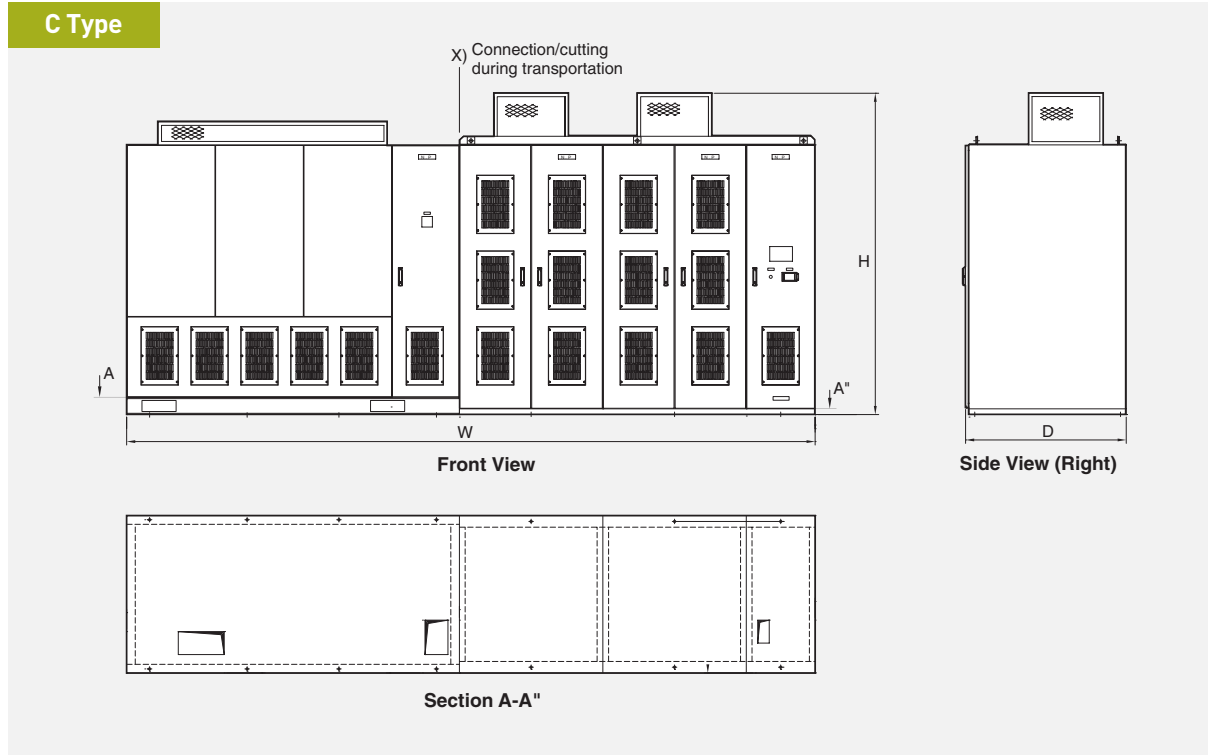

HYUNDAI CLEAN-POWER MV INVERTER



(Unit: mm)

Voltage (V)	Capacity (kVA)	Type	W	H	D	Weight (Approx) (kg)
3300	200	A	2000	2800	1100	2700
	300	A	2000	2800	1100	3000
	400	A	2400	2800	1100	3400
	500	A	2400	2800	1100	3600
	600	B	3300	2800	1100	4300
	750	B	3300	2800	1100	4600
	1000	B	3600	2800	1200	5200
	1250	B	3600	2800	1200	5600
	1500	B	3800	2800	1400	6300
	1750	B	3800	2800	1400	6800
	2000	B	3900	2800	1400	7500
	2250	B	3900	2800	1400	8000
4160	250	B	3200	2800	1100	3900
	380	B	3200	2800	1100	4100
	500	B	3200	2800	1100	4300
	640	B	3200	2800	1100	4600
	750	B	3900	2800	1100	5200
	950	B	3900	2800	1100	5600
	1250	B	4900	2800	1200	6200
	1550	B	4900	2800	1200	6800
	1900	B	5100	2800	1400	8000
	2200	B	5100	2800	1400	8300
	2500	B	5100	2800	1400	8500
	2850	B	5100	2800	1400	9000
6600	400	B	3200	2800	1100	4400
	600	B	3200	2800	1100	5000
	800	B	3900	2800	1100	5700
	1000	B	3900	2800	1100	6000
	1200	C	4900	2800	1100	6800
	1500	C	4900	2800	1100	7300
	2000	C	5100	2800	1200	8500
	2500	C	5100	2800	1200	9000
	3000	C	5200	2800	1400	10000
	3500	C	5700	2800	1400	11000
	4000	C	5900	2800	1400	13000
	4500	C	6000	2800	1400	13500

Components (6.6kV)

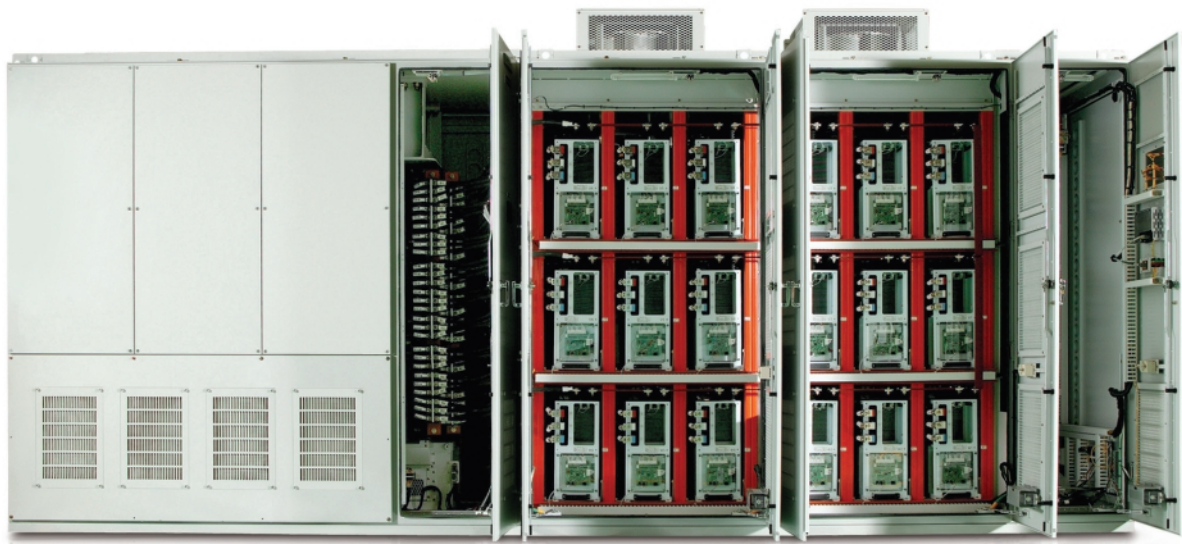

Multi-Winding
Phase-Shifted Transformer

Cell Inverter

Control
Panel

Multi-Winding Phase-Shifted Transformer Section

- ▶ Power supply lead-in terminal and output terminal section to the cell inverter
- ▶ 3.3kV: 9 phase shift windings
- ▶ 6.6kV: 18 phase shift windings
- ▶ Free standing panel type

Power Cell Section

- ▶ 3 or 6 cells connected in series per inverter output phase
- ▶ Modulization of PWM controller and power conversion section
- ▶ 13 level (3.3kV)/25 level (6.6kV) 3 phase direct output

Control Panel

- ▶ Process controller for high speed calculating digital signal process
- ▶ Self-Diagnostic
- ▶ Extendable I/O board
- ▶ CAN communication control and optical signal transmission
- ▶ UPS for back-up of control power *(Option)*

Connection

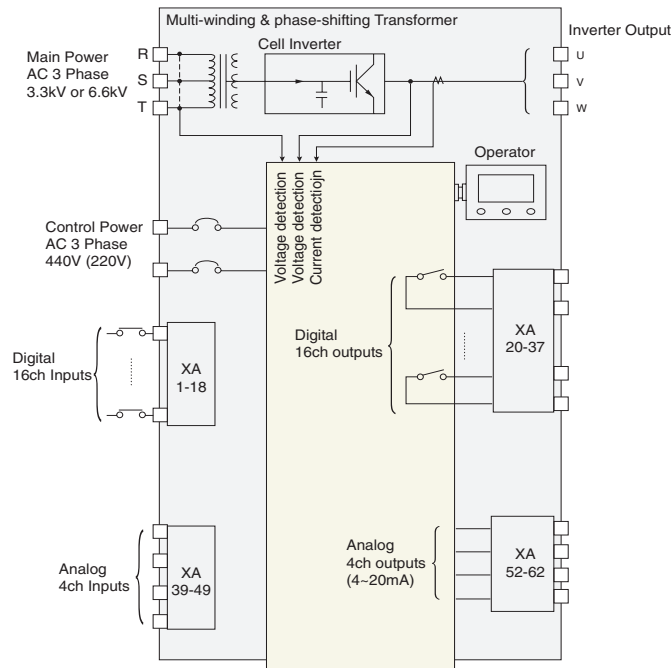

Form for Quotation

※ To get a price quotation, you are required to fill out the following form.

1	Name of Application	
2	Type of Load	<input type="checkbox"/> Pump <input type="checkbox"/> Fan <input type="checkbox"/> Blower <input type="checkbox"/> Compressor <input type="checkbox"/> Others
3	Torque Characteristics	<input type="checkbox"/> Variable Torque <input type="checkbox"/> Proportional Torque <input type="checkbox"/> Constant Torque <input type="checkbox"/> Constant Output $J(GD^2/4) \text{ kg}\cdot\text{m}^2$
4	Operation Conditions	Motor Current _____ A, Annual Operation Time _____ hours
5	Motor Specifications	<input type="checkbox"/> Squirrel-Cage Induction motor <input type="checkbox"/> Wound-Rotor Type Motor <input type="checkbox"/> Existing <input type="checkbox"/> New Output _____ kW, Voltage _____ V, Frequency _____ Hz, Pole Number _____ P Speed _____ min, Rated Current _____ A, Efficiency _____ %, Power Factor _____ %
6	Speed Control Range	Minimum _____ /min to Maximum _____ /min or Minimum _____ /Hz to Maximum _____ /Hz
7	Acceleration/Deceleration Time Setting	Acceleration Time _____ Second(s) / _____ min Deceleration Time _____ Second(s) / _____ min
8	Overload Capacity	_____ % / _____ Second(s)
9	By-Pass Operation Circuit	<input type="checkbox"/> Required < <input type="checkbox"/> Automatic <input type="checkbox"/> Manual >
10	Power Supply Specifications	Power Supply Short-Circuit Capacity _____ MVA, Main Circuit Voltage _____ V, _____ Hz Control Circuit Voltage 200/220V or 400/440V, 50/60Hz
11	Ambient Conditions	Indoors <input type="checkbox"/> Ambient Temperature _____ °C, <input type="checkbox"/> Humidity _____ % or less <input type="checkbox"/> Air-Conditioning Facility (<input type="checkbox"/> Provided <input type="checkbox"/> Not Provided)

www.hyundai-elec.com



Head Office	1, Jeonha-dong, Dong-gu, Ulsan, Korea Tel: 82-52-202-8101~8 Fax: 82-52-202-8100
Seoul (Sales & Marketing)	140-2, Gye-dong, Jongno-gu, Seoul, Korea Tel: 82-2-746-7596, 8451 Fax: 82-2-746-8448
Orlando	3452 Lake Lynda Drive, Suite 170, Orlando, Florida 32817, U.S.A. Tel: 1-407-249-7350 Fax: 1-407-275-4940
New Jersey	300 Sylvan Avenue, Englewood Cliffs, NJ 07632, U.S.A. Tel: 1-201-816-0286 Fax: 1-201-816-4083
London	2nd Floor, The Triangle, 5-17 Hammersmith Grove, London, W6 0LG, UK Tel: 44-20-8741-0501 Fax: 44-20-8741-5620
Tokyo	8th Fl., Yurakucho Denki Bldg. 1-7-1, Yuraku-cho, Chiyoda-gu, Tokyo, 100-0006, Japan Tel: 81-3-3212-2076, 3215-7159 Fax: 81-3-3211-2093
Osaka	I-Room 5th Fl. Nagahori-Plaza Bldg. 2-4-8, Minami Senba, Chuo-Ku, Osaka, 542-0081, Japan Tel: 81-6-6261-5766, 5767 Fax: 81-6-6261-5818
Dubai	Level 2, Unit 205, Emaar Square-Bldg.4 Sheikh Zayed Road, P.O.Box 252458, Dubai, U.A.E. Tel: 971-4-425-7995 Fax: 971-4-425-7996
Sofia	1271, Sofia 41, Rojen Blvd., Bulgaria Tel: 359-2-803-3200 Fax: 359-2-803-3203
Yangzhong	No. 9 Xiandai Road, Xinba Scientific and Technologic Zone, Yangzhong, Jiangsu, P.R.C. Zip: 212212, China Tel: 86-511-8842-0666, 0212 Fax: 86-511-8842-0668, 0231